

## **Health & Safety, Use and Care** and **Installation** guide

Model : AQ5NI24JVS



<https://aristonchannel.com.sg/>



# ARISTON

## REFRIGERATOR-FREEZER

### USE AND CARE GUIDE

#### Table of Contents

<b>REFRIGERATOR SAFETY</b> .....	<b>4</b>
Proper Disposal of Your Old Refrigerator .....	7
<b>PARTS AND FEATURES</b> .....	<b>8</b>
<b>INSTALLATION INSTRUCTIONS</b> .....	<b>9</b>
Getting Started.....	9
Unpack the Refrigerator .....	9
Location Requirements.....	10
Electrical Requirements .....	10
Remove and Replace Refrigerator Doors .....	12
Remove and Replace Freezer/Flexi Freeze Door.....	14
Refrigerator Levelling .....	15
Using the Controls .....	16
Lighting the Refrigerator .....	17
<b>REFRIGERATOR USE</b> .....	<b>18</b>
Opening and Closing Doors .....	18
Food Storage .....	18
<b>SHELVES, BINS AND DRAWERS</b> .....	<b>19</b>
Freezer Storage Compartments .....	20
Audio Reference .....	20
Accessories.....	20
Assistance or Service .....	20
<b>REFRIGERATOR CARE</b> .....	<b>21</b>
Cleaning .....	21
Lights.....	22
Holiday and Moving Care .....	22
<b>TROUBLESHOOTING</b> .....	<b>23</b>

# REFRIGERATOR SAFETY

## Your safety and the safety of others are very important.

We have provided many important safety messages in this manual and on your appliance. Always read and obey all safety messages.



This is the safety alert symbol.

This symbol alerts you to potential hazards that can kill or hurt you and others.

All safety messages will follow the safety alert symbol and either the word "DANGER" or "WARNING."

These words mean:

 **DANGER**

**You can be killed or seriously injured if you don't immediately follow instructions.**

 **WARNING**

**You can be killed or seriously injured if you don't follow instructions.**

All safety messages will tell you what the potential hazard is, tell you how to reduce the chance of injury, and tell you what can happen if the instructions are not followed.

## SAFETY INSTRUCTIONS

Before using the appliance, read these safety instructions. Keep them nearby for future reference. These instructions and the appliance itself provide important safety warnings, to be observed at all times. The manufacturer declines any liability for failure to observe these safety instructions, for inappropriate use of the appliance or incorrect setting of controls.

⚠ Very young children (0-3 years) should be kept away from the appliance. Young children (3-8 years) should be kept away from the appliance unless continuously supervised. Children from 8 years old and above and persons with reduced physical, sensory or mental capabilities or lack of experience and knowledge can use this appliance only if they are supervised or have been given instructions on safe use and understand the hazards involved. Children must not play with the appliance. Cleaning and user maintenance must not be carried out by children without supervision.

### PERMITTED USE

⚠ CAUTION: The appliance is not intended to be operated by means of an external switching device, such as a timer, or separate remote controlled system.

⚠ This appliance is intended to be used in household and similar applications such as: staff kitchen areas in shops, offices and other working environments; farm houses; by clients in hotels, motels, bed & breakfast and other residential environments.

⚠ This appliance is not for professional use. Do not use the appliance outdoors.

⚠ The appliance is designed for operation in places where the ambient temperature comes within the following ranges, according to the climatic class given on the rating plate. The appliance may not work properly if it is left for a long time at a temperature outside the specified range.

Climatic Class Amb. T. (°C)

SN: From 10 to 32 °C; N: From 16 to 32 °C

ST: From 16 to 38 °C; T: From 16 to 43 °C

⚠ This appliance does not contain CFCs. The refrigerant circuit contains R600a (HC). Appliances with Isobutane (R600a): isobutane is a natural gas without environmental impact, but is flammable. Therefore, make sure the refrigerant circuit pipes are not damaged, especially when emptying the refrigerant circuit.

⚠ WARNING: Do not damage the appliance refrigerant circuit pipes.

⚠ WARNING: Keep ventilation openings, in the appliance enclosure or in the built-in structure, clear of obstruction.

## IMPORTANT TO BE READ AND OBSERVED

⚠ WARNING: Do not use mechanical, electric or chemical means other than those recommended by the Manufacturer to speed up the defrost process.

⚠ WARNING: Do not use or place electrical devices inside the appliance compartments if they are not of the type expressly authorised by the Manufacturer.

⚠ WARNING: Ice makers and/or water dispensers not directly connected to the water supply must be filled with potable water only.

⚠ WARNING: Automatic ice-makers and/or water dispensers must be connected to a water supply that delivers potable water only, with mains water pressure between 0.17 and 0.81 MPa (1.7 and 8.1 bar).

⚠ Do not store explosive substances such as aerosol cans with a flammable propellant in this appliance.

⚠ Do not swallow the contents (non-toxic) of the ice packs (provided with some models). Do not eat ice cubes or ice lollies immediately after taking them out of the freezer since they may cause cold burns.

⚠ For products designed to use an air filter inside an accessible fan cover, the filter must always be in position when the refrigerator is in function.

⚠ Do not store glass containers with liquids in the freezer compartment since they may break. Do not obstruct the fan (if included) with food items. After placing the food check that the door of the compartments closes properly, especially the freezer door.

⚠ Damaged gaskets must be replaced as soon as possible.

⚠ Use the fresh food compartment only for storing fresh food and the freezer compartment only for storing frozen food, freezing fresh food and making ice cubes.

⚠ Avoid storing unwrapped food in direct contact with internal surfaces of the fresh food or freezer compartments. Appliances could have special compartments (Fresh Food Compartment, Zero Degree Box, etc.). Unless specified in the specific booklet of product, they can be removed, maintaining equivalent performances.

### INSTALLATION

⚠ The appliance must be handled and installed by two or more persons - risk of injury. Use protective gloves to unpack and install - risk of cuts.

⚠ Installation, including water supply (if any) and electrical connections, and repairs must be carried out by a qualified technician. Do not repair or replace any part of the appliance unless specifically stated in the user manual. Keep children away from the installation site.



After unpacking the appliance, make sure that it has not been damaged during transport. In the event of problems, contact the dealer or your nearest After-sales Service. Once installed, packaging waste (plastic, styrofoam parts etc.) must be stored out of reach of children - risk of suffocation. The appliance must be disconnected from the power supply before any installation operation - risk of electric shock. During installation, make sure the appliance does not damage the power cable - risk of fire or electric shock. Only activate the appliance when the installation has been completed.

⚠ Be careful not to damage the floors (e.g. parquet) when moving the appliance. Install the appliance on a floor or support strong enough to take its weight and in a place suitable for its size and use. Make sure the appliance is not near a heat source and that the four feet are stable and resting on the floor, adjusting them as required, and check that the appliance is perfectly level using a spirit level. Wait at least two hours before switching the appliance on, to ensure that the refrigerant circuit is fully efficient.

⚠ To guarantee adequate ventilation, leave a space on both sides and above the appliance. The distance between the rear of the appliance and the wall behind the appliance should be 50mm, to avoid access to hot surfaces. A reduction of this space will increase the Energy consumption of product.

⚠ **WARNING:** To avoid a hazard due to instability, positioning or fixing of the appliance must be done in accordance with the manufacturer instructions. It is forbidden to place the refrigerator in such way that the metal hose of gas stove, metal gas or water pipes, or electrical wires are in contact with the refrigerator back wall (condenser coil).

⚠ If it is necessary to replace the doors, please contact the Technical Assistance Center.

### **ELECTRICAL WARNINGS**

⚠ It must be possible to disconnect the appliance from the power supply by unplugging it if plug is accessible, or by a multi-pole switch installed upstream of the socket in accordance with the wiring rules and the appliance must be earthed in conformity with national electrical safety standards.

⚠ Do not use extension leads, multiple sockets or adapters. The electrical components must not be accessible to the user after installation. Do not use the appliance when you are wet or barefoot. Do not operate this appliance if it has a damaged power cable or plug, if it is not working properly, or if it has been damaged or dropped.

⚠ If the supply cord is damaged, it must be replaced with an identical one by the manufacturer, its service agent or similarly qualified persons in order to avoid a hazard - risk of electric shock.

⚠ **WARNING:** When positioning the appliance, ensure the supply cord is not trapped or damaged.

⚠ **WARNING:** Do not locate multiple portable socket-outlets or portable power supplies at the rear of the appliance.

### **CLEANING AND MAINTENANCE**

⚠ **WARNING:** Ensure that the appliance is switched off and disconnected from the power supply before performing any maintenance operation; never use steam cleaning equipment - risk of electric shock.

⚠ Do not use abrasive or harsh cleaners such as window sprays, scouring cleansers, flammable fluids, cleaning waxes, concentrated detergents, bleaches or cleansers containing petroleum products on plastic parts, interior and door liners or gaskets. Do not use paper towels, scouring pads, or other harsh cleaning tools.

### **DISPOSAL OF PACKAGING MATERIALS**

The packaging material is 100% recyclable and is marked with the recycle symbol ♻.

The various parts of the packaging must therefore be disposed of responsibly and in full compliance with local authority regulations governing waste disposal.

### **DISPOSAL OF HOUSEHOLD APPLIANCES**

This appliance is manufactured with recyclable or reusable materials. Dispose of it in accordance with local waste disposal regulations. For further information on the treatment, recovery and recycling of household electrical appliances, contact your local authority, the collection service for household waste or the store where you purchased the appliance. This appliance is marked in compliance with European Directive 2012/19/EU, Waste Electrical and Electronic Equipment (WEEE). By ensuring this product is disposed of correctly, you will help prevent negative consequences for the environment and human health.

The symbol ⚡ on the product or on the accompanying documentation indicates that it should not be treated as domestic waste but must be taken to an appropriate collection center for the recycling of electrical and electronic equipment.

### **ENERGY SAVING TIPS**

Install the appliance in a dry, well ventilated room far away from any heat source (eg. radiator, cooker, etc.) and in a place not exposed directly to the sun. If required, use an insulating plate.

To guarantee adequate ventilation follow installation instructions. Insufficient ventilation at the back of the product increases energy consumption and decreases cooling efficiency.

Frequent door opening might cause an increase in Energy Consumption. The internal temperature of the appliance and the Energy Consumption may be affected also by the ambient temperature, as well as location of the appliance. Temperature setting should take into consideration these factors.

Reduce door opening to a minimum.

When thawing frozen food, place in the refrigerator. The low temperature of the frozen products cools the food in the refrigerator. Allow warm food and drinks to cool down before placing in the appliance.

Positioning of the shelves in the refrigerator has no impact on the efficient usage of energy. Food should be placed on the shelves in such way to ensure proper air circulation (food should not touch each other and distance between food and rear wall should be kept).

You can increase storage capacity of frozen food by removing baskets and, if present, Stop Frost shelf.

Do not worry about noises coming from the compressor which are described as normal noises in this product's Quick Guide.



## Proper Disposal of Your Old Refrigerator

### **⚠ WARNING**

#### **Suffocation Hazard**

**Remove doors from your old refrigerator.**

**Failure to do so can result in death or brain damage.**

**IMPORTANT:** Child entrapment and suffocation are not problems of the past. Scrapped or abandoned refrigerators are still dangerous—even if they will sit for “just a few days.” If you are getting rid of your old refrigerator, please follow these instructions to help avoid accidents.

#### **Before You Throw Away Your Old Refrigerator or Freezer:**

- Take off the doors.
- Leave the shelves in place so that children cannot easily climb inside.

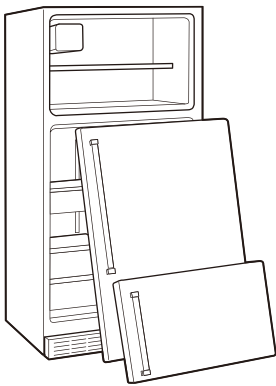

#### **Important information to know about disposal of refrigerants:**

Dispose of refrigerator in accordance with Federal and Local regulations. Refrigerants must be evacuated by a licensed, refrigerant technician in accordance with established procedures.

# PARTS AND FEATURES

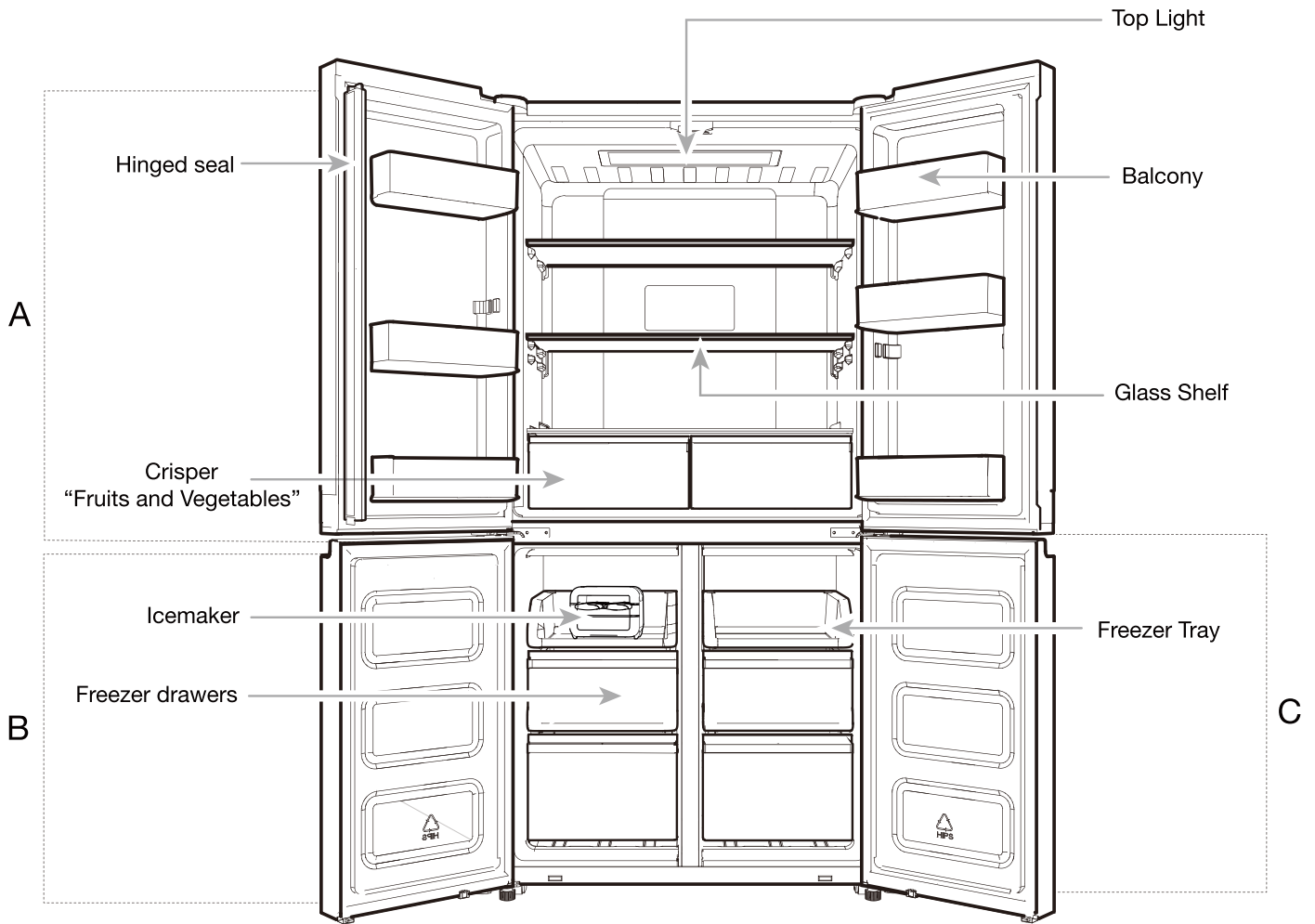

- A . Fresh Food Compartment
- B . Freezer Compartment
- C . Flexi Freeze Compartment

**NOTE FOR SERVICE:**

Center divider can be removed by taking out the 3 screws on the right side (see picture below); With the center divider removed the evaporator area can be reached for service.

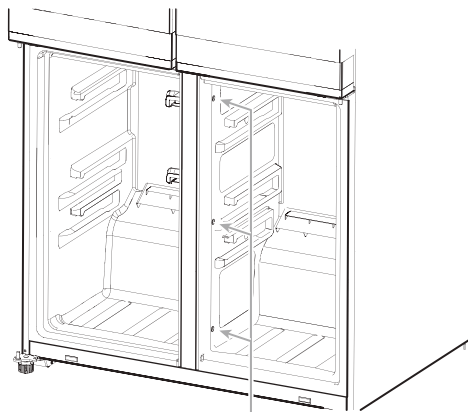

Screw Location

**STORAGE CAPACITY:**

Fresh Food Compartment	384 L
Freezer Compartment	207 L
Total	591 L

# INSTALLATION INSTRUCTIONS

## Getting Started INSTALLATION CHECKLIST

### ✓ Electrical Power

#### **⚠ WARNING**



#### **Electrical Shock Hazard**

- Plug into a grounded (earthed) outlet.**
- Do not remove ground prong.**
- Do not use an adapter.**
- Do not use an extension cord.**
- Failure to follow these instructions can result in death, fire, or electrical shock.**

- Plug refrigerator into a earthed socket.
- ### ✓ Doors
- If doors need to be removed during installation, see the “Remove and Replace Refrigerator Doors” and “Remove and Replace Freezer Door Fronts” sections.
  - Doors seal completely.
  - Refrigerator is level. Adjust leveling feet so they are snug against the floor.
  - Doors are even across the top. (Use door alignment feature if necessary).
- ### ✓ Final Checks
- Remove all shipping material.
  - Set temperature controls to the recommended setting.
  - Save instructions and other literature.
  - In order to receive a more complete assistance, please register your product on <http://www.arisitwarranties.com.au>

## Unpack the Refrigerator

#### **⚠ WARNING**

#### **Excessive Weight Hazard**

- Use two or more people to move and install refrigerator.**
- Failure to do so can result in back or other injury.**

### Refrigerator Delivery

A minimum door opening of 838 mm (33") is required. If door opening is 914 mm (36") or less, then removal of doors, drawer and hinges is required.

Cart the refrigerator from the side for all door openings.

#### **When Moving Your Refrigerator:**

Your refrigerator is heavy. When moving the refrigerator for cleaning or service, be sure to cover the floor with cardboard or hardboard to avoid floor damage. Always pull the refrigerator straight out when moving it. Do not wiggle or “walk” the refrigerator when trying to move it, as floor damage could occur.

### Remove the Packaging

- Remove tape and glue residues from surfaces before turning on the refrigerator. Rub a small amount of liquid dish detergent over the adhesive with your fingers. Wipe with warm water and dry.
- Do not use sharp instruments, rubbing alcohol, flammable fluids, or abrasive cleaners to remove tape or glue. These products can damage the surface of your refrigerator.
- Dispose of/recycle all packaging materials.

### Clean Before Using

After you remove all of the packaging materials, clean inside of your refrigerator before using it. See cleaning instructions in the “Refrigerator Care” section.

#### **Important information to know about glass shelves and covers:**

Do not clean glass shelves or covers with warm water when they are cold. Shelves and covers may break if exposed to sudden temperature changes or impact, such as bumping. Tempered glass is designed to shatter into many small, pebble-size pieces. This is normal. Glass shelves and covers are heavy. Use both hands when removing them to avoid dropping.

## Location Requirements

### **⚠ WARNING**



#### Explosion Hazard

Keep flammable materials and vapors, such as gasoline, away from refrigerator.

Failure to do so can result in death, explosion, or fire.

To ensure proper ventilation for your refrigerator, allow for a 1.25 cm space on each side and at the top. Allow for a 5 cm space behind the refrigerator. If your refrigerator has an ice maker, allow extra space at the back for the water line connections. When installing your refrigerator next to a fixed wall, leave a 9.5 cm minimum space between the refrigerator and wall to allow the door to swing open.

**NOTE:** This refrigerator is intended for use in a location where the temperature ranges from a minimum of 10°C to a maximum of 43°C. The preferred room temperature range for optimum performance, which reduces electricity usage and provides superior cooling, is between 15°C and 32°C. It is recommended that you do not install the refrigerator near a heat source, such as an oven or radiator.

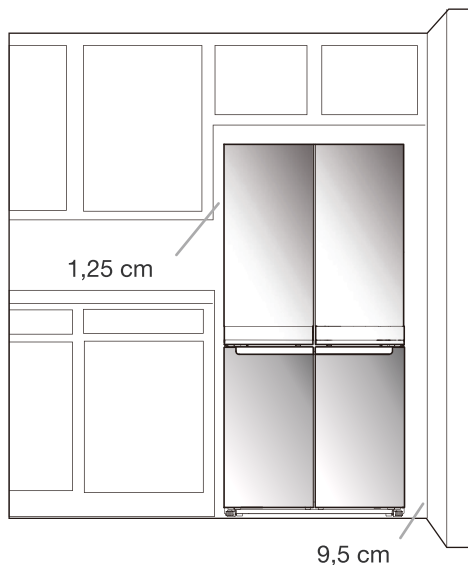

## Electrical Requirements

### **⚠ WARNING**



#### Electrical Shock Hazard

Plug into a grounded (earthed) outlet.

Do not remove ground prong.

Do not use an adapter.

Do not use an extension cord.

Failure to follow these instructions can result in death, fire, or electrical shock.

**IMPORTANT:** Installation and the electrical connection must be carried out by a qualified technician according to the manufacturer's instructions and in compliance with the local safety regulations.

- The refrigerator is designed to operate on a separate 220-240 Volt, 10 A, 50-60 Hz circuit.
- Make sure voltage specified on the rating plate corresponds to that of your home.
- It must be possible to disconnect the appliance from power supply by unplugging it or by means of a main two pole switch installed upstream of the socket.
- If supply cord is damaged, it must be replaced by the manufacturer, its service agent or similarly qualified persons in order to avoid a hazard.

Before you move your refrigerator into its final location, it is important to make sure you have the proper electrical connection:

#### Recommended Earthing Method

220-240 Volt 50 Hz, 220 Volt 60 Hz, or 230/240 Volt 50 Hz AC only 10 A fused and earthed electrical supply is required.

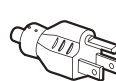

Type B

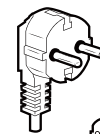

Type E and F



Type I

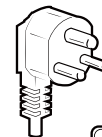

Type M

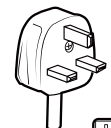

Type G

#### For Australia and New Zealand:

Your new appliance has been especially manufactured to meet all Australian Standards and Conditions.

Some notations in the installation instructions may refer to electrical requirements in other countries, so we draw your particular attention to these specific notes.

Your appliance needs to be plugged into a 230/240 Volt 50 Hz AC only 10 A earthed socket.

---

## Electrical Requirements

---

**IMPORTANT:** This refrigerator must be earthed.

### Fuse Replacement

If the main lead of this refrigerator is fitted with a BS1363A, 13 A fused plug, to replace a fuse in this type plug use an A.S.T.A. approved fuse to BS 1362 type and proceed as follows:

1. Remove the fuse cover (A) and fuse (B).
2. Fit replacement 13 A fuse into the fuse cover.
3. Reinsert both the fuse and its cover into the plug.

**IMPORTANT:** The fuse cover must be refitted when changing a fuse. If the fuse cover is lost, the plug must not be used until a correct replacement cover is fitted. A correct replacement is identified by the colour insert or the colour "word" embossed on the base of the plug. Replacement fuse covers are available at your local electrical shop.

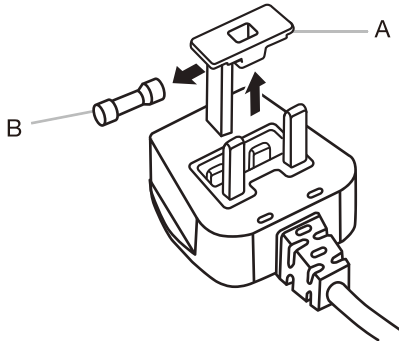

A. Fuse cover  
B. Fuse

### For the Republic of Ireland:

The information given in respect of Great Britain will frequently apply, but a third type of plug and socket is also used, the 2-pin, side earth type.

### Socket/Plug

If fitted plug is not suitable for your socket, please contact After-sales Service for further instruction. Please do not attempt to change plug yourself. This procedure needs to be carried out by a qualified technician in compliance with the manufacturer's instructions and current standard safety regulations.

---

## Temperature

---

This refrigerator is designed for operation in places where temperature comes within the following ranges, according to climatic class shown on the rating plate. The refrigerator may not work properly if it is left for a long time at a temperature outside the specified range.

**NOTE:** It is recommended that you do not install the refrigerator near a heat source, such as an oven or radiator.

Climatic Class	Amb. T. (°C)	Amb. T. (°F)
SN	From 10 to 32	From 50 to 90
N	From 16 to 32	From 61 to 90
ST	From 16 to 38	From 61 to 100
T	From 16 to 43	From 61 to 110



## Remove and Replace Refrigerator Doors

**NOTE:** Measure the width of your door opening to see whether or not you need to remove refrigerator doors to move refrigerator into your home. If door removal is necessary, see the following instructions.

**IMPORTANT:** If refrigerator was previously installed and you are moving it out of the home, turn refrigerator control off before you begin removing the doors. Unplug refrigerator or disconnect power. Remove food and adjustable door or utility bins from doors.

Gather required tools and read all instructions before removing doors.

**TOOLS NEEDED:** 6 mm socket wrench, 5 mm socket wrench and a #2 Phillips screwdriver.



### **WARNING**

#### Electrical Shock Hazard

Disconnect power before removing doors.

Failure to do so can result in death or electrical shock.

#### Top Left Hinge Cover

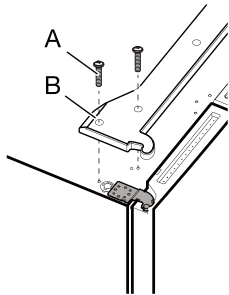

A. Top Hinge Cover screws  
B. Top Hinge Cover

#### Top Right Hinge Cover

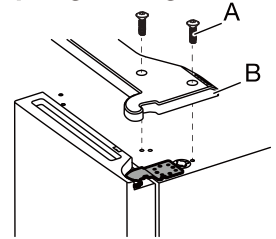

A. Top Hinge Cover screws  
B. Top Hinge Cover

#### Top Left Hinge

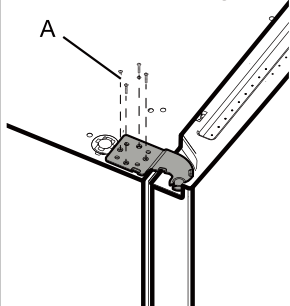

A. 5 mm socket screws

#### Top Right Hinge

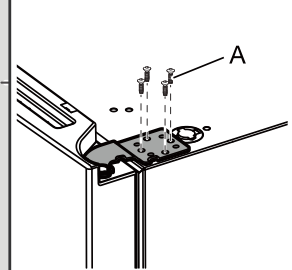

A. 5 mm socket screws

#### Middle Left Hinge

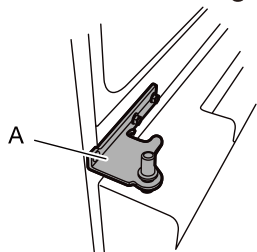

A. Hinge

#### Middle Right Hinge

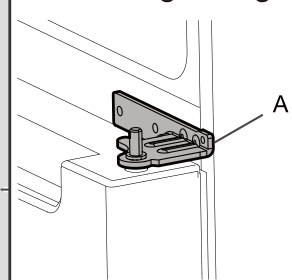

A. Hinge

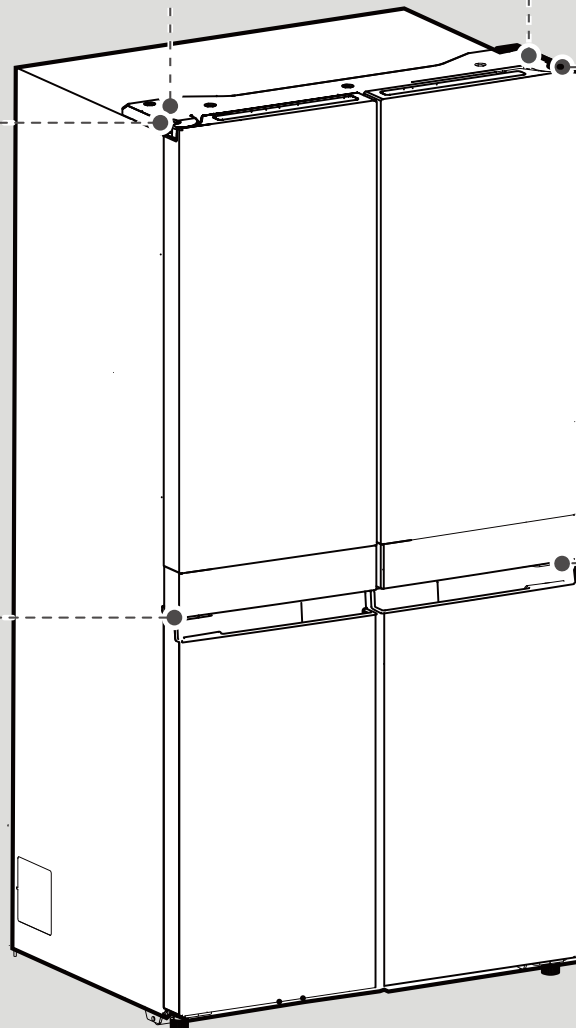

## ⚠ WARNING

### Excessive Weight Hazard

Use two or more people to lift the refrigerator door.  
Failure to do so can result in back or other injury.

## Remove Refrigerator Doors

## ⚠ WARNING



### Electrical Shock Hazard

Disconnect power before removing doors.  
Failure to do so can result in death or electrical shock.

## Remove Right-Hand Door

1. Unplug refrigerator or disconnect power.
2. Keep refrigerator doors closed until you are ready to lift them free from the cabinet.

**NOTE:** Provide additional support for refrigerator door while the hinges are being removed. Do not depend on door gasket magnets to hold the door in place while you are working.

3. Using a Phillips screwdriver, remove cover from top hinge.
4. Using 5 mm socket wrench, remove four screws from top hinge and set aside.

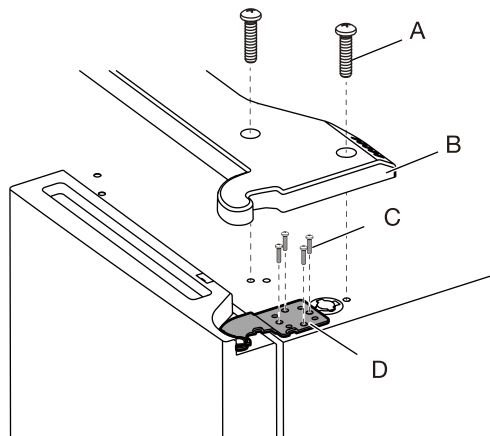

- A. Top hinge cover screw  
B. Top hinge cover  
C. 5 mm socket screws  
D. Top hinge

5. Lift the refrigerator door from the middle hinge pin. The top hinge will come away with the door.

## Remove Left-Hand Door

**IMPORTANT:** The wiring for UI run through left-hand door hinge, so they must be disconnected before removing the door.

1. Using a Phillips screwdriver, remove cover from top hinge.

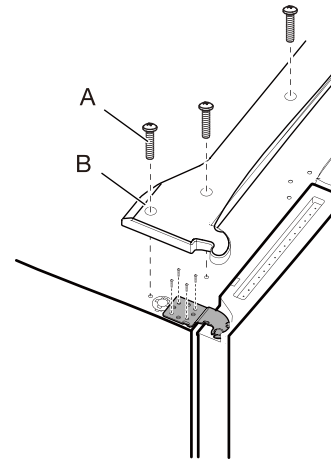

- A. Top hinge cover screw  
B. Top hinge cover

2. Disconnect two wiring plugs located on top of the door hinge.
  - Grasp each side of wiring plugs. With your left thumb, press down to release the catch and pull the sections of the plugs apart.

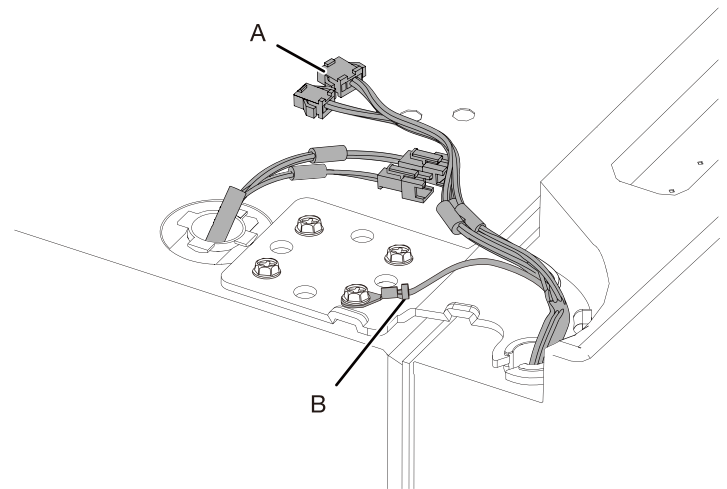

- A. Wiring Plug  
B. Ground (earth) connector

- Using 5 mm socket wrench, remove four internal screws from top hinge and set aside.

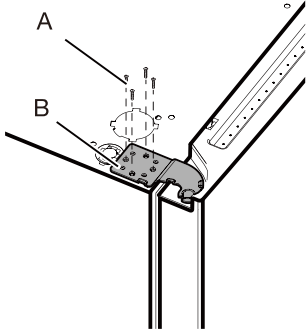

A. 5mm socket screws  
B. Top Hinge

**NOTE:** Provide additional support for refrigerator door while hinges are being removed. Do not depend on door gasket magnets to hold door in place while you are working.

- Lift refrigerator door from bottom hinge pin. The top hinge will come away with the door.

**NOTE:** It may not be necessary to remove bottom hinges and brake feet assemblies to move refrigerator through a doorway.

- Only if necessary, use 6 mm socket wrench and #2 Phillips screwdriver to remove middle hinge.

#### Replace Right-Hand Refrigerator Door

- Set right-hand door onto middle hinge pin.
- Insert top hinge pin into open hole in the top of refrigerator door.
- Using four 5 mm socket screws, fasten hinge to the cabinet. Do not tighten the screws completely.

#### Replace Left-Hand Refrigerator Door

- Set left-hand door onto middle hinge pin.
- Using four 5 mm socket screws, fasten hinge to the cabinet. Do not tighten the screws completely.
- Reconnect electrical wiring.
  - Push together two sections of wiring plug.
  - Reconnect earth wire to hinge screw.

#### Final Steps

- Completely tighten eight 5 mm socket screws.
- Replace top hinge covers.

## Remove and Replace Freezer/Flexi Freeze Door

- Keep freezer doors closed until you are ready to lift them free from the cabinet.

**NOTE:** Provide additional support for freezer door while hinges are being removed. Do not depend on door gasket magnets to hold the door in place while you are working.

- Using a #2 Phillips screwdriver and 6 mm socket wrench to remove the middle hinge from the cabinet.

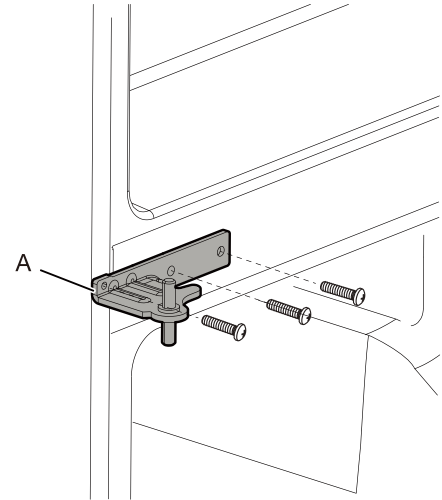

A. Middle hinge

- Lift freezer door from bottom hinge pin.

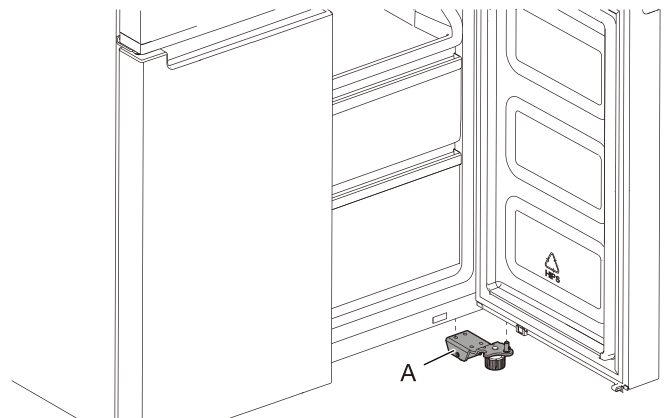

A. Bottom hinge

## ⚠ WARNING



### Electrical Shock Hazard

Plug into a grounded (earthed) outlet.

Do not remove ground prong.

Do not use an adapter.

Do not use an extension cord.

Failure to follow these instructions can result in death, fire, or electrical shock.

1. Plug into an grounded (earthed) socket.
2. Return all removable parts and food to the drawers.

## Refrigerator Levelling

1. Move refrigerator to its final location.
2. Using hand, rotate brake feet. Turn them counterclockwise until rollers are off the floor and both brake feet are snug against the floor. This keeps the refrigerator from rolling forward when opening the doors.

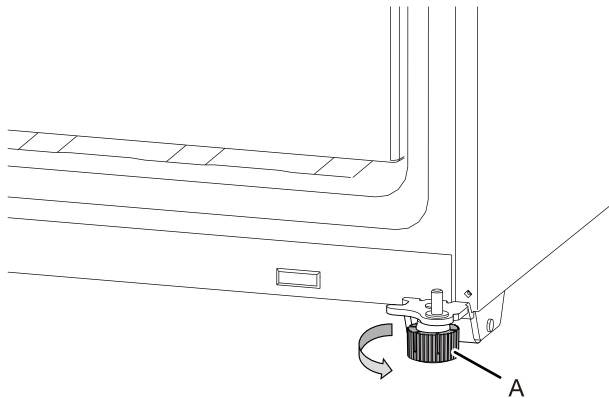

A. Brake feet

**IMPORTANT:** If you need to make further adjustments involving the brake feet, you must turn both brake feet same amount to keep the refrigerator level.

3. Use a level to make sure refrigerator is level from side to side and front to back.

## Using the Controls

The touch-activated controls are located on left hand refrigerator door. The control panel includes information about various buttons and indicators. Refrigerator and freezer temperature indicator shows the last temperature set point.

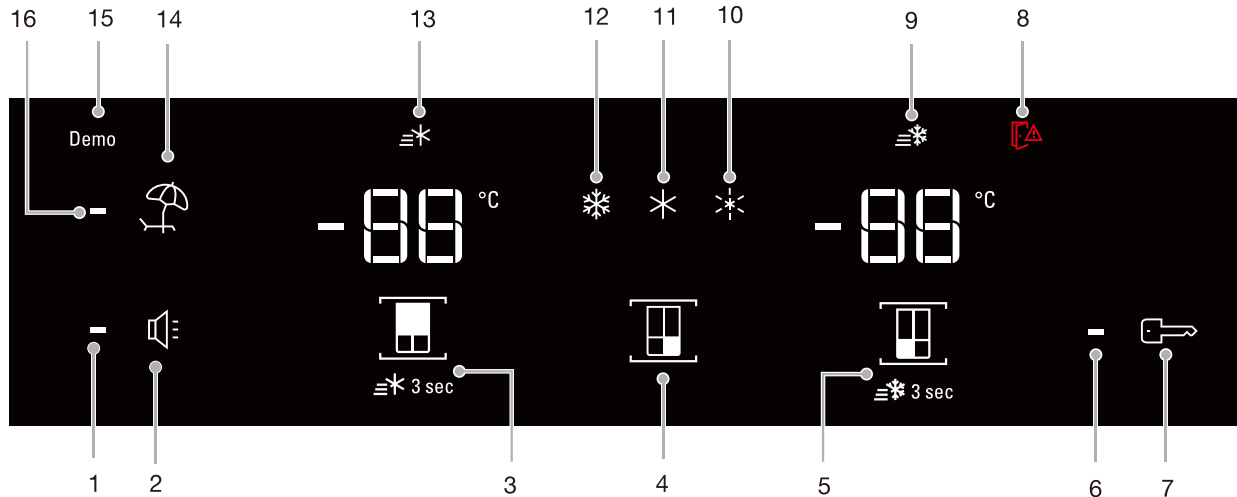

1. Sound Indicator
2. Sound ON/OFF Button
3. Refrigerator Temperature Button (hold 3 sec for Fast Cool)
4. Flexi Freeze Preset Temperature Button
5. Freezer Temp Button (hold 3 sec for Fast Freeze)
6. Key Lock Indicator
7. Key Lock Button
8. Door Open Indicator

9. Fast Freeze Indicator
10. Soft Freeze Indicator
11. Mild Freeze Indicator
12. Traditional Freeze Indicator
13. Fast cool Indicator
14. Holiday Mode Button
15. Demo mode Indicator
16. Holiday Mode Indicator (hold 3 sec)

The Control Panel will automatically turn off after one minute of inactivity. To turn on the control panel, press any key.

### -88 Viewing and Adjusting Temperature Set Points

#### Adjusting Fresh Food and Freezer Compartment Temperature:

For your convenience, your refrigerator and freezer controls are preset at the factory.

When you first install your refrigerator, make sure that the controls are still set to the recommended set points. The factory recommended set points are 3°C for the refrigerator and -18°C for the freezer.

Pressing the Refrigerator or Freezer Temperature button will toggle through temperature set points in Celsius (°C)

#### IMPORTANT:

- Wait 24 hours before you put food into refrigerator. If you add food before refrigerator has cooled completely, your food may spoil.  
**NOTE:** Adjusting set points to a colder-than recommended setting will not cool the compartments any faster.
- If the temperature is too warm or too cold in refrigerator or freezer, first check the air vents to be sure they are not blocked before adjusting the controls.
- The recommended settings should be correct for normal household use. The controls are set correctly when milk or juice is as cold as you like and when ice cream is firm.  
**NOTE:** Areas such as a garage, basement or porch may have higher humidity or extreme temperatures. You may need to adjust the temperature away from the recommended settings to accommodate for these conditions.
- Wait at least 24 hours between adjustments. Recheck the temperatures before other adjustments are made.

### ❄️ ❄️ ❄️ Flexi Freeze Setting

Flexi Freeze function allows you to toggle preset temperature for Flexi freeze compartment.

Symbol	Function	Temperature
❄️	Traditional freezer	-18°C
❄️	Mild freezer	-12°C
❄️	Soft freezer	-7°C

\* To activate/deactivate Coolest setting (-20°C), press Flexi Freeze Preset Temperature Button for 3 seconds. When the Coolest setting is activated, all three icons ❄️ ❄️ ❄️ will be lit.

### Adjusting Multi Temperature Setting



- Traditional freezer (-18°C): Food already frozen and fresh food (max 12 months)
- Mild freezer (-12°C): Food already frozen (max 1 month)
- Soft freezer (-7°C): Food already frozen (max 1 week)
- When Flexible Freezer temperature is set to -18°C or -20°C, both Flexible Freezer temperature and Freezer temperature would be cooled down to the colder setting whichever Freezer or Flexible Freezer has.
- Flexible Freezer compartment temperature might not be able to reach -7°C when the ambient temperature is around 10°C or colder.

When adjusting temperature set points, use the following chart as a guide:

CONDITION	TEMPERATURE ADJUSTMENT
Refrigerator too cold	Refrigerator setting 1° higher
Refrigerator too warm	Refrigerator setting 1° lower
Freezer too cold	Freezer setting 1° higher
Freezer too warm/ too little ice	Freezer setting 1° lower



### Fast Cool

The Fast Cool feature assists with periods of high refrigerator use, full grocery loads, or temporarily warm room temperatures.

- To turn on the Fast Cool feature, press and hold the Refrigerator Temperature button  for 3 seconds. When feature is activated, the Fast Cool icon will be illuminated. The Fast Cool feature will remain on for 2 hours unless manually turned off.
- To manually turn off the Fast Cool feature, press and hold the Refrigerator Temperature button  for 3 seconds. The Fast Cool icon will turn off when the feature is not activated.
- Adjusting the refrigerator temperature will automatically turn off the Fast Cool feature.

### Fast Freeze

The amount of fresh food (in kg) that can be frozen in 24 hours is indicated on the appliance rating plate.

- Press Freezer Temperature button  for 3 seconds (until the Fast Freeze Indicator lights up), 24 hours before placing fresh food in freezer. After placing fresh food in freezer, 24 hours on Fast Freeze function is generally sufficient; After 50 hrs the fast freeze function automatically deactivates.
- To manually turn off the Fast Freeze feature, press and hold the Freezer Temperature button  for 3 seconds. The Fast Freeze icon will turn off.
- Adjusting the freezer temperature will automatically turn off the Fast Freeze feature.

### Holiday Mode

This mode is designed to avoid your appliance from wasting energy during times when it's not in regular use (when you are in holiday for example).

By selecting this function the temperature of fresh food compartment will automatically be set to 12°C.

- To use Holiday mode, press the mode button and hold for 3 seconds until the Holiday mode indicator is lit on the display.
- To exit Holiday mode, press the Holiday mode button and hold for 3 seconds until no mode icon is lit on the display.
- Adjusting the refrigerator temperature will automatically turn off the Holiday Mode feature.

**IMPORTANT: If this mode is selected then all food and drinks must be removed from the fresh food compartment.**

### Sound ON/OFF

Press button to activate/deactivate Sound Feedback.

### Key Lock

- Press and hold the Lock button for 3 seconds to activate lock feature.
- To deactivate lock, press and hold the Lock button for 3 seconds.

The lock feature will ignore all interaction with control panel until user unlocks the control panel. This feature is meant to avoid unintentional changing of settings.

### Demo Mode

This mode is used when refrigerator is on display in a retail shop or if you want to turn the cooling off and deactivate all other functions (except interior lighting).

Demo mode can be used when going on extended holiday. See the “Holiday and Moving Care” section for proper steps on leaving your refrigerator in this mode for long periods of time.

- If you turn on Demo mode, the “Demo” icon will light up on the display.
- Enter or exit Demo mode by pressing and holding the Sound On or Off button and the Lock button simultaneously for 3 seconds.

## Additional features

### Door Open Alarm

- The Door Open Alarm feature sounds an alarm and blinks the “Door Open” icon  when any of the four doors is open for 2 minutes or more.
- The alarm will repeat every 5 minutes. Close all doors to turn it off.

**NOTE:** To mute audible alarm while keeping doors open, such as while cleaning inside of refrigerator, touch any button on the control panel. The alarm sound will be temporarily turned off, but the Door Open icon will still be displayed on the control panel.

## Lighting the Refrigerator

The refrigerator has an interior light that comes on any time the door is opened.

**NOTE:** The light is LED which does not need to be replaced. If the LED does not illuminate when the door is opened, call service to replace light.



# REFRIGERATOR USE

## Opening and Closing Doors

There are two fresh food compartment doors. The doors can be opened and closed either separately or together. There is a vertically hinged seal on the left refrigerator door.

- When left-side door is opened, the hinged seal automatically folds inward so that it is out of the way.
- When both doors are closed, the hinged seal automatically forms a seal between two doors.

**NOTE:** When closing the door, the hinged seal should be in correct position (be bent inside). Otherwise it will hit the right door or the fixing shaft.

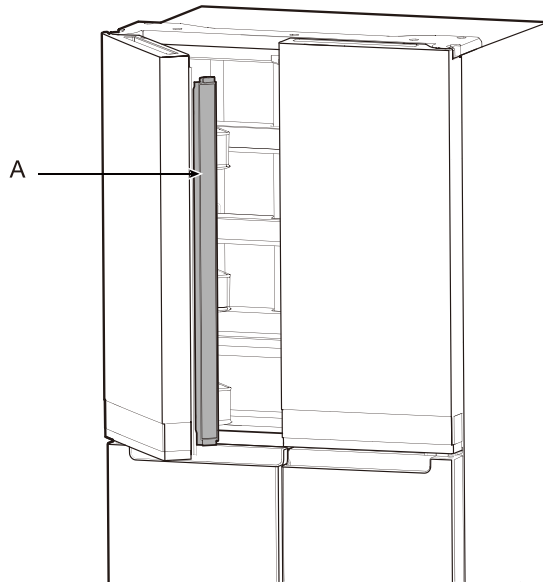

A. Hinged seal

The fresh food compartment door switch is located in top left and right hinge cover.

- For Freezer and Multi Temperature Zone, door switch is located in the bottom mullion.
- The door switch uses magnet to sense door opening/closing.
- Ensure there are no magnet or electronic devices (Speaker, CoolVox® etc.) within 7.62 cm of the hinge cap.

**NOTE:** The light will not turn on if the door opening is not detected.

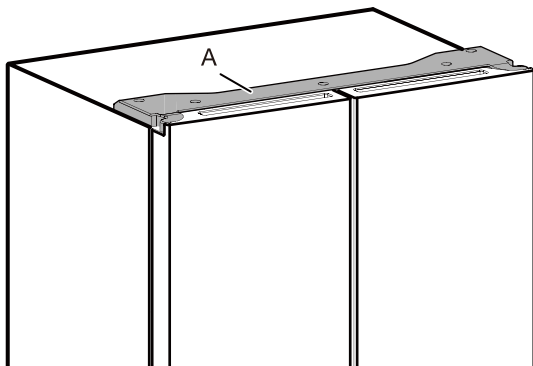

A. Hinge cover

## Ice Maker

- To make ice, fill ice tray with purified water and place Manual Ice maker into Freezer top shelf. Allow time till ice gets formed and once ice is ready, turn the knobs in clockwise direction to eject ice cubes into the ice container.

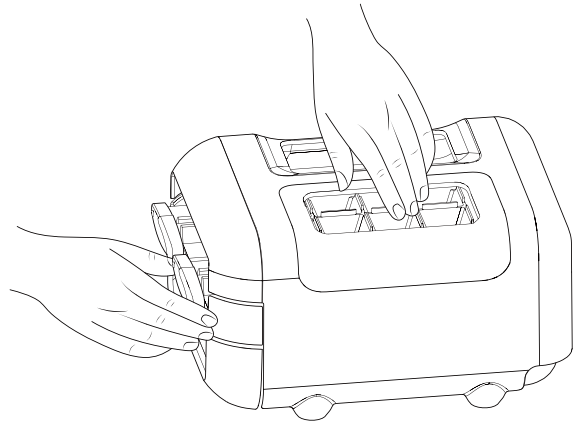

- Lift ice container slightly and pullout ice container to get access to ice cubes.

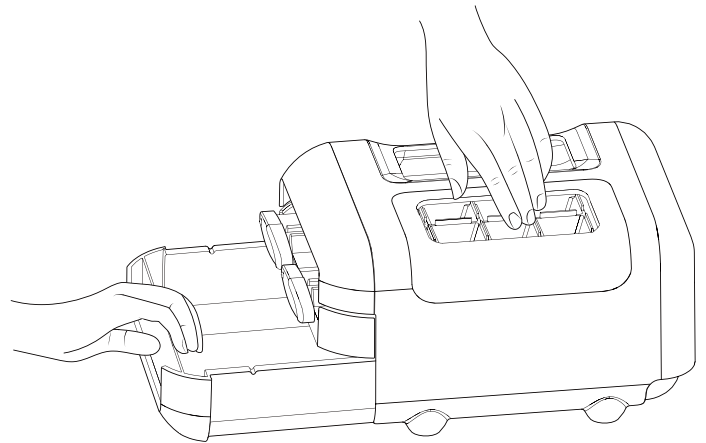

Manual ice maker assembly can be taken out of the freezer when ice is not required to make more compartment in freezer.

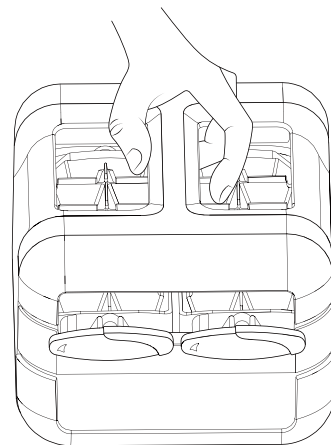

## Food Storage

### Egg Storage

It is recommended to store eggs at a consistent temperature to keep its freshness, so best is to keep them in the fridge on the middle shelf.

# SHELVES, BINS AND DRAWERS

## Important information to know about glass shelves and covers:

Do not clean glass shelves or covers with warm water when they are cold. Shelves and covers may break if exposed to sudden temperature changes or impact, such as bumping. Tempered glass is designed to shatter into many small, pebble-size pieces. This is normal. Glass shelves and covers are heavy. Use both hands when removing them to avoid dropping.

## Shelf Height Adjustment

Shelf height can be adjusted by changing its location from bottom support to upper support and vice versa

- Open right side door to its full opening.
- Open left side door to its full opening.

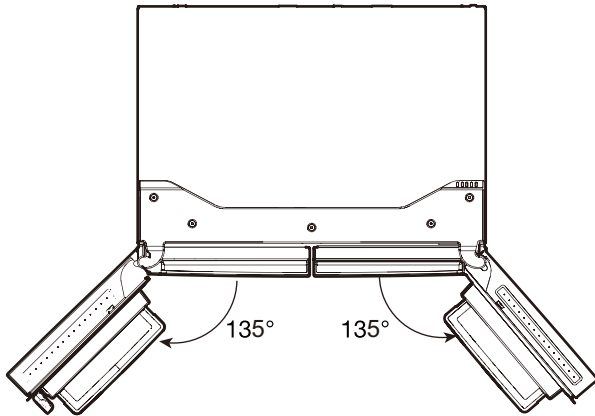

- Take shelf out of refrigerator and place it to desired mounting position.

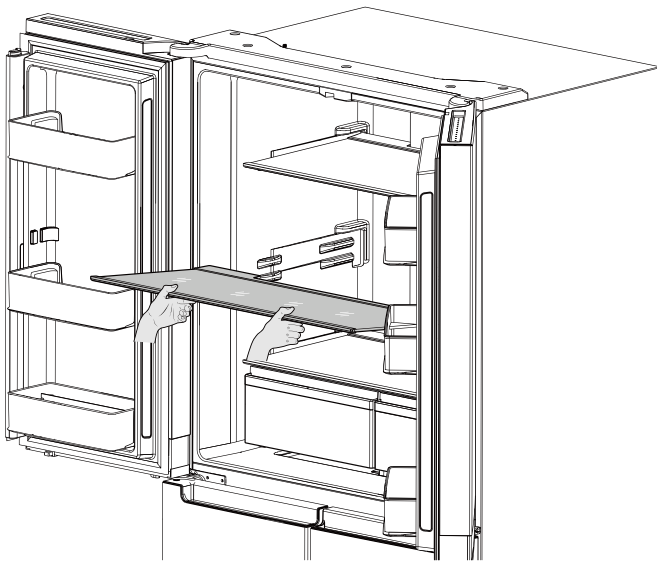

- Ensure shelf is properly seated on shelf mounts.

## Shelves and Shelf Frames

The shelves in your refrigerator are adjustable to meet your individual storage needs.

Storing similar food items together in your refrigerator and adjusting the shelves to fit different heights of items will make finding the exact item you want easier. It will also reduce the amount of time the refrigerator door is open and save energy.

### To remove and replace shelves:

1. Open right side door to its full opening and left side door to its full opening.
2. Remove the middle shelf or top shelf by lifting it up and out of shelf supports. Then pull the shelf forward and tilt down to a vertical position. Turn shelf at an angle and pull out of refrigerator.
3. Remove the bottom shelf by lifting it up and out of shelf supports. Then pull shelf forward and tilt up to a vertical position. Turn shelf at an angle and pull out of refrigerator.
4. Replace middle and top shelves by putting shelf in refrigerator at an angle with shelf front down. Lift front of shelf up and slide in until rear of shelf drops into shelf supports. Lower front of shelf and make sure that shelf is in position.
5. Replace bottom shelf by putting the shelf in refrigerator at an angle with shelf up. Lift front of shelf down and slide in until rear shelf drops into shelf supports. Lower front of shelf and make sure that shelf is in position.

## Crispers

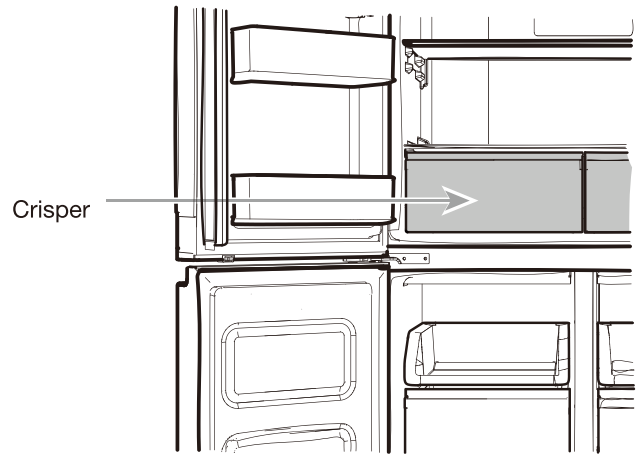

### To remove and replace the Crispers:

1. Grasp handle of the Crisper and slide the Crisper straight out to the stop. Lift the Crisper off the bottom guide.
2. Replace/putting back the Crisper by placing it on the bottom Crisper guide and pushing it past the Crisper stop into position.

## Refrigerator Balconies

The balcony on your refrigerator door are adjustable to meet your individual storage needs.

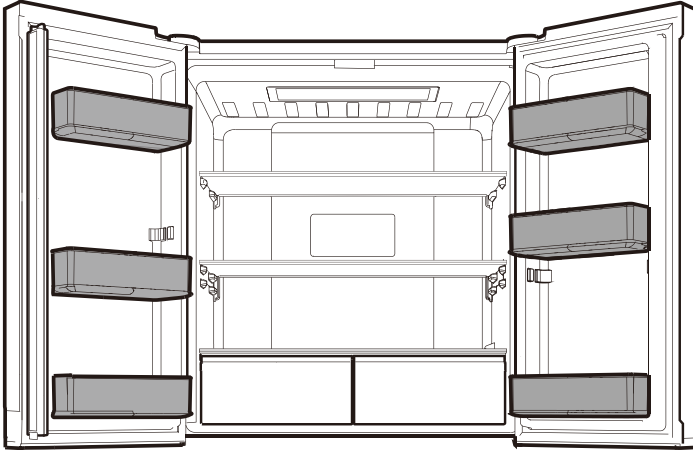

## Freezer Storage Compartments

### Freezer Tray

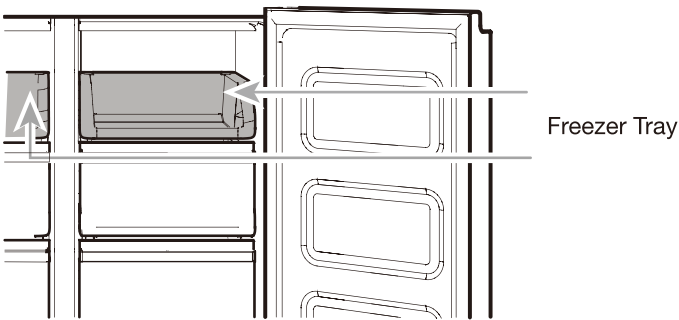

Freezer tray is useful to easily access frequently used products, freeze or simply store leftovers or small items.

### Freezer Drawer

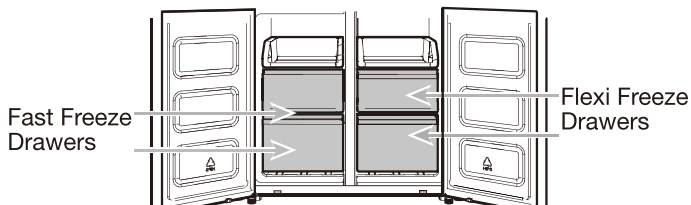

### Fast Freeze compartment

- Fast Freezer drawers allows you to conveniently store big volume items.
- Fast Freeze option allows you to store all your frozen food safely and transparently.

**NOTE:** Freezer temperature might be cooled down to be same as Flexible Freezer Compartment temperature, when Freezer set to warmer than Flexible Freezer compartment.

### Flexi Freeze Compartment

Flexi Freeze Compartment allows you to select one of three freezer temperature levels:  $-7^{\circ}\text{C}$ ,  $-12^{\circ}\text{C}$ ,  $-18^{\circ}\text{C}$  and  $-20^{\circ}\text{C}$  to provide the best storing conditions for different types of food.

For maximum freezer capacity, you may remove freezer drawer to expose the freezer shelf.

### To remove the upper drawer:

1. Grasp handle of the drawer and slide drawer straight out to the stop. Lift drawer off the bottom guide
2. Replace/putting back drawer by placing it on bottom drawer guide and pushing it past drawer stop into position.

## Audio Reference

### Tone Assignment

Tone Name	Usage Examples
Power On	Cooling system is turned on every time the product is powered on.
Key Press	User presses a valid button.
Invalid (Error)	User presses two or more valid buttons at the same time. Count-down interruption for press-and-hold buttons.
Engage	Acknowledgement of entry into any mode.
Disengage	Acknowledgement of exit from any mode.
Alert	Door Ajar alert.

This table is for quick reference only. See corresponding sections for details. In case of inconsistency, section details will prevail.

## Accessories

To order accessories, contact the dealer from whom you purchased your refrigerator.

## Assistance or Service

Before calling for assistance or service, please check the "Troubleshooting" section. It may save you the cost of a service call. If you still need help, follow the instructions below.

### If you need replacement parts

To locate factory-specified replacement parts in your area, contact the dealer from whom you purchased your refrigerator.

### Warranty

Contact the dealer from whom you purchased the refrigerator for warranty information.

**Keep this book and your sales slip together for future reference. You must provide proof of purchase or installation date for in-warranty service.**

Write down the following information about your appliance to help you obtain assistance or service if you ever need it. You will need to know your complete model number and serial number. You can find this information on the model and serial number label, located on the inside wall of the fresh food compartment.

Dealer name \_\_\_\_\_

Serial number \_\_\_\_\_

Address \_\_\_\_\_

Phone number \_\_\_\_\_

Model number \_\_\_\_\_

Purchase date \_\_\_\_\_

# REFRIGERATOR CARE

## Cleaning

### **WARNING**



#### Explosion Hazard

Use nonflammable cleaner.

Failure to do so can result in death, explosion, or fire.

All of the Refrigerator, Freezer and Flexi freeze sections defrost automatically. However, clean all the sections about once a month to avoid build-up of odours. Wipe up spills immediately.

### Exterior Cleaning

Please see exterior cleaning information specific to your model.

#### Style 1 – Smooth Door

**IMPORTANT:** Damage to smooth finish due to improper use of cleaning products or using non-recommended cleaning products is not covered under the warranty. Sharp or blunt instruments will mar the finish.

DO USE	DO NOT USE
✓ Soft, clean cloth	<ul style="list-style-type: none"> <li>✗ Abrasive cloths</li> <li>✗ Paper towels or newsprint</li> <li>✗ Steel-wool pads</li> </ul>
✓ Warm, soapy water with a mild detergent	<ul style="list-style-type: none"> <li>✗ Abrasive powders or liquids</li> <li>✗ Window sprays</li> <li>✗ Ammonia</li> <li>✗ Acidic or vinegar-based Cleaners</li> <li>✗ Oven cleaners</li> <li>✗ Flammable fluids</li> </ul>

**NOTE:** Paper towels scratch and may dull the clear coat of the painted door. To avoid possible damage, use only soft, clean clothes to polish and wipe the doors.

#### Style 2 – Stainless Steel

##### IMPORTANT:

- Use recommended stainless steel cleaners and cloths only. Damage to stainless steel finish due to improper use of cleaning products or using non-recommended cleaning products is not covered under the warranty.
- Avoid exposing stainless steel appliances to caustic or corrosive elements such as high-salt, high-moisture, or high-humidity environments. Damage due to exposure to these elements is not covered under the warranty.

DO USE	DO NOT USE
✓ Soft, clean cloth	<ul style="list-style-type: none"> <li>✗ Abrasive cloths</li> <li>✗ Paper towels or newsprint</li> <li>✗ Steel-wool pads</li> </ul>
✓ Warm, soapy water with a mild detergent	<ul style="list-style-type: none"> <li>✗ Abrasive powders or liquids</li> <li>✗ Ammonia</li> <li>✗ Citrus-based cleaners</li> <li>✗ Acidic or vinegar-based cleaners</li> <li>✗ Oven cleaners</li> </ul>
✓ For heavy soil, use only a stainless steel cleaner designed for appliances. To order the cleaner, contact the dealer from whom you purchased your refrigerator.	✗ Stainless steel cleaner is for stainless steel parts only. Do not allow the stainless steel cleaner and polish to come into contact with any plastic parts such as the trim pieces, dispenser covers, or door gaskets.

#### Style 3 – Fingerprint-Resistant Stainless

##### IMPORTANT:

- Avoid exposing stainless steel appliances to caustic or corrosive elements such as high-salt, high-moisture, or high-humidity environments. Damage due to exposure to these elements is not covered under the warranty.

DO USE	DO NOT USE
✓ Soft, clean cloth	<ul style="list-style-type: none"> <li>✗ Abrasive cloths</li> <li>✗ Paper towels or newsprint</li> <li>✗ Steel-wool pads</li> </ul>
✓ Warm, soapy water with a mild detergent	<ul style="list-style-type: none"> <li>✗ Abrasive powders or liquids</li> <li>✗ Window sprays</li> <li>✗ Ammonia</li> <li>✗ Acidic or vinegar-based cleaners</li> <li>✗ Oven cleaners</li> <li>✗ Flammable fluids</li> </ul>

##### NOTES:

- If unintentional contact does occur, clean plastic part with a sponge and mild detergent in warm water. Dry thoroughly with a soft cloth.
- Just because a cleaner is a liquid does not mean it is non-abrasive. Many liquid cleansers formulated to be gentle on tile and smooth surfaces still damage stainless steel.
- Citric acid permanently discolours stainless steel.
- To avoid damaging the finish of your stainless steel refrigerator:

##### Do not allow these substances to remain on the finish:

- |                  |                         |
|------------------|-------------------------|
| ✗ Mustard        | ✗ Citrus-based sauces   |
| ✗ Tomato juice   | ✗ Citrus-based products |
| ✗ Marinara sauce |                         |

---

## Interior Cleaning

---

1. Unplug refrigerator or disconnect power.
2. Hand wash, rinse, and dry removable parts and interior surfaces thoroughly. Use a clean sponge or soft cloth and a mild detergent in warm water.  
**NOTE:** Do not use abrasive or harsh cleaners such as window sprays, scouring cleansers, flammable fluids, cleaning waxes, concentrated detergents, bleaches, or cleansers containing petroleum products on plastic parts, interior and door liners, or gaskets.
3. Plug in refrigerator or reconnect power.

---

## Condenser

---

This refrigerator has skin condenser on both sides of refrigerator. It is normal to feel warm on the sides.

---

## Lights

---

The lights in both fresh food and freezer compartments are LEDs which do not need to be replaced. If the lights do not illuminate when the door is opened, contact the dealer from whom you purchased your refrigerator.

---

## Holiday and Moving Care

---

---

### Holidays

---

#### If You Choose to Leave the Refrigerator On While You're Away:

1. Use up any perishables and freeze other items.
2. If your refrigerator has an automatic ice maker and is connected to the household water supply, turn off the water supply to refrigerator. Property damage can occur if water supply is not turned off.
3. If you have an automatic ice maker, turn off ice maker.
  - Press the switch to Off (O) for door ice maker.
4. Empty the ice bin.

#### If You Choose to Turn Off the Refrigerator Before You Leave:

**NOTE:** Put refrigerator in Demo Mode while on Holiday. See the "Using the Controls" section.

1. Remove all food from refrigerator.
2. If your refrigerator has an automatic ice maker:
  - Turn off water supply to ice maker at least 1 day ahead of time.
  - When last load of ice drops, press switch to Off (O) for display to be unlit on the top inside of refrigerator, depending on your model.
3. Empty ice bin (if equipped).
4. Turn off temperature controls. See "Using the Controls" section.
5. Clean refrigerator, wipe it and dry well.
6. Tape rubber or wood blocks to the tops of both doors to prop them open far enough for air to get in. This stops odours and mould from building up.

---

## Moving

---

When you are moving your refrigerator to a new home, follow these steps to prepare it for the move.

1. If your refrigerator has an automatic ice maker:
  - Turn off water supply to the ice maker at least 1 day ahead of time.
  - Disconnect water line from the back of the refrigerator.
  - When last load of ice drops, press switch to Off (O) either on ice maker or the control, depending on your model.
2. Remove all food from refrigerator and pack all frozen food in dry ice.
3. Empty ice bin (if equipped).
4. Unplug refrigerator.
5. Clean, wipe and dry thoroughly.
6. Take out all removable parts, wrap them well and tape them together so they don't shift and rattle during the move.
7. Depending on model, raise front of refrigerator so it rolls more easily or raise levelling screws so they do not scrape the floor. See the "Adjust the Doors" or "Refrigerator Levelling and Door Closing" sections.
8. Tape doors closed and tape the power cable to the back of the refrigerator.

When you get to your new home, put everything back and refer to the "Installation Instructions" section for preparation instructions. Also, if your refrigerator has an automatic ice maker, remember to reconnect the water supply to the refrigerator.



# TROUBLESHOOTING

First try the solutions suggested here to possibly avoid a service call.

**⚠ WARNING**



**Electrical Shock Hazard**

**Plug into a grounded (earthed) outlet.**

**Do not remove ground prong.**

**Do not use an adapter.**

**Do not use an extension cord.**

**Failure to follow these instructions can result in death, fire, or electrical shock.**

If you experience	Possible Causes	Solution
<b>Refrigerator Operation</b>		
The refrigerator will not operate.	Check electrical supply.	Plug the power cable into an earthed socket.
		Do not use an extension cable.
		Make sure there is power to the socket. Plug in a lamp to see if the socket is working.
		Reset a tripped circuit breaker. Replace any blown fuses. <b>NOTE:</b> If problems continue, contact an electrician.
	Check controls.	Make sure the controls are turned on. See “Using the Controls” section.
New installation	Allow 24 hours following installation for refrigerator to cool completely. <b>NOTE:</b> Adjusting temperature controls to the coldest setting will not cool either compartment more quickly.	
Refrigerator control is in Demo mode.	If refrigerator is in Demo mode, cooling is turned off and “Demo” will be illuminated on control panel. See the “Using the Controls” section for more information.	
The motor seems to run too much.	High-efficiency compressor and fans	Larger, more efficient refrigerators run longer at lower, more energy efficient speeds.
	The room or outdoor temperature is hot.	It is normal for refrigerator to work longer under these conditions. For optimum performance, place refrigerator in an indoor, temperature-controlled environment. See the “Location Requirements” section.
	A large amount of warm food has been recently added.	Warm food will cause the refrigerator to run longer until air cools to the desired temperature.
	The door(s) are opened too frequently or for too long.	Warm air entering the refrigerator causes it to run more. Open the door less often.
	The refrigerator door or freezer drawer is open.	Make sure refrigerator is level. See “Refrigerator Levelling and Door Closing” section. Keep food and containers from blocking the door.
	The refrigerator control is set too cold.	Adjust refrigerator control to a less-cold setting until refrigerator temperature is as desired.
	The door or drawer gasket is dirty, worn, or cracked.	Clean or change gasket. Leaks in the door seal will cause refrigerator to run longer in order to maintain desired temperatures.



# TROUBLESHOOTING

First try the solutions suggested here to possibly avoid a service call.

If you experience	Possible Causes	Solution
The lights do not work.	Your refrigerator is equipped with LED lighting which does not need to be replaced.	If there is power to refrigerator and lights do not illuminate when a door or drawer is opened, call for service or assistance.
	Doors have been open longer than 10 minutes.	Close doors and drawer to reset and open to resume lighted task.
	The door switch is not sensing the door opening.	Ensure there are no magnets or electronic devices within 7.6 cm (3") of the hinge cover.
The Temperature Control UI does not turn on.	The Temperature Control UI went to sleep.	Press any button on the UI to wake up the The Temperature Control UI.
	The Temperature Control UI buttons are not working well.	Try cycling power on the refrigerator to make the buttons reset. If problem continuous, call for service or assistance.
	The Temperature Control UI is not receiving power.	Check the wiring harness at the door hinge.
Unable to adjust setting on The Temperature Control UI.	Door is open and Door ajar alarm is activated.	Close the door.
<b>Unusual Noise</b>		
To listen to normal refrigerator sounds, go to the Product Help/FAQ section of the brand website and search for "normal sounds." Below are listed some normal sounds with explanations.		
The refrigerator seems noisy.	The compressor in your new refrigerator regulates temperature more efficiently while using less energy and operates quietly.	Due to this reduction in operating noise, you may notice unfamiliar noises that are normal.
Sound of the compressor running longer than expected.	High-efficiency compressor and fans.	Larger, more-efficient refrigerators run longer at lower, more energy efficient speeds.
Pulsating/Whirring	Fans/compressor adjusting to optimize performance during normal compressor operation.	This is normal.
Popping	Contraction/expansion of inside walls, especially during initial cool down.	This is normal.
Hissing/Dripping	Flow of refrigerant or flow of oil in the compressor.	This is normal.
Vibration	The refrigerator may not be steady.	Adjust the levelling screws and lower the levelling foot firmly against the floor. See the "Refrigerator Levelling and Door Closing" section.
Sizzling	Water dripping on the heater during Defrost cycle.	This is normal.
Water running/Gurgling	May be heard when ice melts during the Defrost cycle and water runs into the drain pan.	This is normal.

# TROUBLESHOOTING

First try the solutions suggested here to possibly avoid a service call.

If you experience	Possible Causes	Solution
<b>Temperature and Moisture</b>		
Temperature is too warm.	The refrigerator has just been installed.	Allow 24 hours following installation for refrigerator to cool completely.
	The controls are not set correctly for the surrounding conditions.	Adjust the controls a setting colder. Check temperature in 24 hours. See the "Using the Controls" section.
	The door(s) are opened often or not closed completely. Allows warm air to enter refrigerator.	Minimize door openings and keep doors fully closed.
	A large load of food was recently added.	Allow several hours for refrigerator to return to normal temperature.
	Demo mode is on.	Turn off the Demo mode. See the "Using the Control" section.
	Holiday mode is on.	Turn off the Holiday mode. See the "Using the Control" section.
Temperature is too cold in the refrigerator/crisper.	The refrigerator air vent(s) are blocked.	If air vent located in the middle rear of fresh food compartment is blocked by items placed directly in front of it, the refrigerator will get too cold. Move items away from the air vent.
	The controls are not set correctly for the surrounding conditions.	Adjust controls a setting warmer. Check temperature in 24 hours. See "Using the Controls" section.
Temperature is too cold in the temperature controlled drawer.	The control is not set correctly for the items stored in drawer.	Adjust temperature setting. See the "Using the Controls" in the "Refrigerator Use" section.
There is interior moisture build-up. <b>NOTE:</b> Some moisture build-up is normal.	The room is humid.	A humid environment contributes to moisture build-up.
	The door(s) are opened often or not closed completely. Allows humid air to enter the refrigerator.	Minimize door openings and close doors completely.
	The door(s) are blocked open.	Move food packages away from door.
	A bin or shelf is in the way.	Push bin or shelf back into the correct position.
	Storing liquid in open containers.	This adds humidity to the refrigerator interior. Keep all containers tightly covered.
There is frost/ice build-up in the freezer compartment.	The door is opened often or left open.	Minimize door openings and close drawer completely after use.
	The door has poor door seal.	Ensure door seals are making full contact with the refrigerator cabinet to allow for an adequate seal.
	Temperature controls are not set correctly.	See the "Using the Controls" section for recommended temperature settings.

# TROUBLESHOOTING

First try the solutions suggested here to possibly avoid a service call.

<b>⚠ WARNING</b>

<p><b>Explosion Hazard</b></p> <p><b>Use nonflammable cleaner.</b></p> <p><b>Failure to do so can result in death, explosion, or fire.</b></p>

If you experience	Possible Causes	Solution
<b>Doors</b>		
The doors will not close completely.	The door is blocked open.	Move food packages away from door.
	A bin or shelf is in the way.	Push bin or shelf back into the correct position.
	Recently installed.	Remove all packaging materials.
The doors are difficult to open.	The door gaskets are dirty or sticky.	Clean gaskets and contact surfaces with mild soap and warm water. Rinse and dry with soft cloth.
The doors appear to be uneven.	The doors need to be aligned or the refrigerator needs to be levelled.	If you need to align door please call for service.
The refrigerator is unsteady or it rolls forward when opening and closing doors.	The refrigerator brake feet are not snug against the floor.	Turn both brake feet (one on each side) counterclockwise, the same amount, until they are snug against the floor. See the "Refrigerator Levelling and Door Closing" section.

---

EN CH