

Visit
www.aristonchannel.com.sg/warranty-registration
to register your product warranty online.

For more information, please contact our Customer Service Hotline +65 6250 6888 or email
helpdesk.sg@whirlpool.com

Important Notice: Warranty is only valid and applicable to Ariston products purchased from authorized retailers in Singapore. Please retain your original receipt and present it for verification when required. Whirlpool Southeast Asia Pte reserves the right to reject warranty claims not registered online.

Ariston® Registered trademark
All rights reserved - <http://www.aristonchannel.com.sg>
註冊商標/惠而浦集團的TM商標
版權所有 翻印必究 - <http://www.aristonchannel.com.sg>

EN

 **ARISTON**

 **ARISTON**

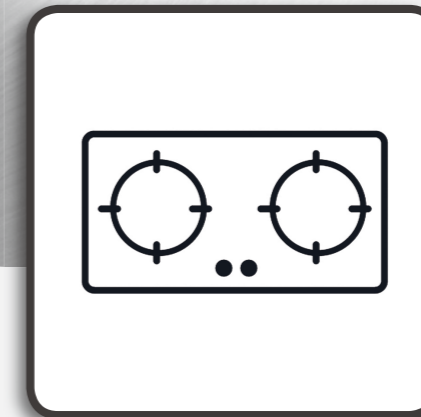

Health & Safety, Use & Care, Installation Guide and Online Warranty Registration Information

GAS COOKER

Model: AGG2780TS / AGG2780LS
AGG3780TS / AGG3780LS
AGG3880TS / AGG3880LS



www.aristonchannel.com.sg

Table of Contents

	page
Important Safety Instructions	02-03
Installation Instructions	04-07
Cleaning Tips	07
Safeguarding The Environment	08
Product Outlook	08
Useful Advice For Using The Burners	09
How to Use The Hob	09-10
Troubleshooting Guide	10
Technical Specifications	11
After-sales Service	12

Destination country: Singapore

IMPORTANT SAFETY INSTRUCTIONS

YOUR SAFETY AND THE SAFETY OF OTHERS ARE VERY IMPORTANT

This manual and the appliance itself provide important safety messages, to be read and observed at all times.



This is the safety alert symbol, pertaining to safety, which alert users to potential hazards to themselves and others. All safety messages will follow the safety alert symbol and either the terms:



DANGER

Indicates a hazardous situation which, if not avoided, will cause serious injury.



WARNING

Indicates a hazardous situation which, if not avoided, could cause serious injury.

All Safety messages will tell you what the potential hazard is, tell you how to reduce the chance of injury, and tell you what can happen if the instructions are not followed.



WARNING

If the information in this manual is not followed exactly, a fire or explosion may result causing property damage or injury.

- Do not store or use gasoline or other flammable vapors and liquids in the vicinity of this appliance.

What to do if you smell gas:

- Do not try to light any appliance.
- Do not touch any electrical switch.
- Do not use any phone in your building.
- Close the gas valve, leave the scene and then call your gas supplier.
- If you cannot reach your gas supplier, call the police department.
- Use appliance in well ventilated rooms only.
- This appliance has been designed for home use only.
- Do not use this appliance as a space heater to heat or warm the room. Doing so may result in carbon monoxide poisoning and overheating of the hob. The Manufacturer declines all responsibility for inappropriate use or incorrect setting of the controls.
- The appliance is not intended for use by persons (including children) with reduced physical, sensory or mental capabilities, or with lack of experience and knowledge of the appliance, unless supervised or previously instructed in its use by those responsible for their safety.
- Young children should be kept away from the appliance and be supervised to ensure that they do not play with it.
- The use of a gas appliance produces heat and humidity in the room. Make sure the room is well-ventilated, or install an extractor hood with exhaust duct.
- In case of prolonged use, additional ventilation may be necessary (by opening a window or increasing the hood extraction speed).
- After use, make sure the knobs are in off position and close the main gas supply cock or the gas cylinder valve.
- Overheated oils and fats may catch fire easily. Always remain vigilant when cooking foods rich in fat, oil or alcohol (e.g. rum, cognac, wine).
- Keep the packaging materials out of the reach of children.
- Before cleaning or maintenance, wait for hob to cool down.
- This product is not intended to be installed and operated outdoors.
- After ignition, make sure the burner ignites and flame stays even and normal.
- Before removing cookware from the burner, always set burner to small flame or turn it off.
- Do not use oversize or over weight cooking pot or receptacles. Or it will damage the grid and cause excessive heat to be reflected back onto the range surface. This may increase the temperature of this area and may cause damage.
- Contact Ariston After-Sales Service for repair or parts replacement. During guarantee period, Whirlpool Southeast Asia Pte. will reserve the right to charge for spare parts and service fees if the damage is caused by misuse or service providers improper installation.
- Maximum load weight for this gas hob is 10kg.
- Do not use oversized utensils for cooking , utensil size should be less than 34cm.
- Cooking vessels on the hotplate should not overlap its edges.

CAUTION FOR GLASS TOP HOBS

- Do not place anything (e.g. flame tamer or asbestos mat) between the pan and pan support, as serious damage to the appliance may result.



- Do not remove the pan support and enclose the burner with a wok stand, as this will concentrate and deflect the heat onto the hotplate.



- Do not use large pots or heavy weights that can bend the pan support or deflect flame onto the hotplate.



- Locate the pan centrally over the burner so that it is stable and does not overhang the appliance.



- Use only a wok support supplied or recommended by the manufacturer of the appliance.



SUITABLE PANS (FOR THE USE OF FLAT BOTTOM PAN ONLY)



Burner	Minimum pan diameter (cm)	Maximum pan diameter (cm)
Wok Burner	Ø 18 (When using pans below 12cm please use the pan adapter provided)	Ø 30
Small Burner	Ø 10	Ø 20

- Refer to the chart above and ensure that the pan diameter falls within the minimum and maximum diameters given for the burner you are using. A pan which is too small will be unstable on the pan support. If the pan base diameter is too large, flames can spread out to the sides and damage or burn the worktop, wall claddings or surrounding units and also parts of the hob. The manufacturer cannot be held liable for this type of damage.
- Select pans which are suitable for the burner they are to be used on. In general: use larger diameter pans on the large burners, and smaller diameter pans on the small burners.
- Pans with thick bases are preferable as these distribute heat more evenly. With thin bases, there is a danger of food overheating in places. Stir the food frequently.
- Any heat-resistant pans can be used on a gas burner.

USAGE OF ASSISTANT PAN SUPPORT

- When the diameter of the utensils used is less than 100 mm, the assistant pan support should be placed on the main pan support. After confirming that the placement is stable, the pot can be placed on an assistant pan support for use.



When placing pans on the pan support(s) make sure you position them so that they cannot tip up. Please note that it is not possible to prevent pans from wobbling very slightly. Always place pans on the pan support(s) supplied. Pans must not be placed directly on the burner.

INSTALLATION INSTRUCTIONS

Attention:

Any gas installation works including the installation of appliances and connection tubing, must be undertaken by registered gas installers who are registered for that appropriate classes and be employed by registered gas contractors.

After unpacking the hob, make sure that it has not been damaged during transport. In the event of problems, contact the dealer or Ariston After-Sales Service.

When installing built-in gas hob on top of stove cabinet, please check that there is provision for ventilation at the cabinet to ensure proper operation of the gas hob.

Do not store any flammable materials, sprays or pressurized containers inside the stove cabinet.

Gas connections must comply with local regulations.

- The manufacturer cannot be held responsible for any injury to persons or animals or damage to property arising from failure to comply with these requirements.

TECHNICAL INFORMATION FOR THE INSTALLER

- Use protective gloves for handling, preparing and installing the product.
- Before installation, make sure that:
 - The local gas delivery conditions (nature and pressure) are compatible with the settings of the hob (see the rating plate mark on the gas hob);
 - The outer surfaces of the furniture or appliances adjacent to the hob are heat resistant according to local regulations;
 - This appliance is not connected to a fume exhaust device. It shall be installation regulations. Particular attention shall be given to the relevant requirements regarding ventilation;
 - Combustion products are discharged outdoors through specific hoods or wall and / or window mounted electrical fans.

INSTALLATION ATTENTION

The gas cooking range must be installed by registered gas installer. Otherwise, the manufacturer will not be responsible for any damages.

- Prior to installation, ensure that the appliance is adjusted for the type of gas with which it is to be supplied according to the local distribution conditions (nature of the gas and gas pressure).
- Install the built-in hob in a well ventilated room and keep it away from any combustible or inflammable objects such as paper or oil.
- Place the built-in hob on a stable and level surface.
- If the unit to be installed close to combustible surroundings (such as wooden walls, wooden shelves), it should be installed at least 150mm (6") from the side walls. The unit should be installed with a distance of at least 150mm away from surrounding combustible materials.
- At least keep 25mm (1") distance from bottom.
- External gas governor is not required.
- This appliance shall be installed in accordance with the regulations in force and only used in a well ventilated space. Read the instructions before installing or using this appliance.
- The adjustment conditions for this appliance are stated on the label (or data plate).
- This appliance is not connected to a combustion products evacuation device. It shall be installed and connected in accordance with current installation regulations. Particular attention shall be given to the relevant requirements regarding ventilation.

EXPLOSION HAZARD

- All gas supply connections must be tightened, when installing this product.
- After being tightened, all gas supply connections must be examined by soapy water to ensure no bubble and leakage.
- Failure to do so can result in death or fire.

I. Room Ventilation

Give the kitchen the amount of air required for regular gas combustion and for the room to keep well-ventilated. Air must naturally flow through permanent opening in the walls of the room, and ensure that they may never be blocked. Indirect ventilation by air drawn from an adjacent room is also permitted, in strict compliance with any local regulation in force.

II. Gas Connection

Before connecting the appliance, check that the specifications on the data label affixed to the underside of the hob correspond to those of the gas and electricity mains in the house. A label on the appliance indicates the regulating conditions: Type of gas and working pressure. Gas connection must comply with the pertinent standards and provisions in force. The size of the gas inlet is 1/2 inch.

A. LPG Connection

- Tubing connection: please use approved flexible tubing bearing SPRING approval marking (e.g. "SPRING APPROVAL GTXXXX") accessories and gas cock for connecting from back of the unit to the gas supply point.
- Stainless steel braided flexible hose connection: Please use approved stainless steel braided flexible tubing bearing SPRING approval marking (e.g. "SPRING APPROVAL GTXXXX") accessories and gas cock for connecting from 1/2 inch B.S.P at back of the unit to the gas supply point.

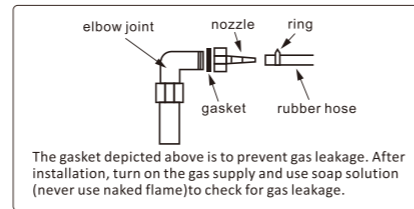

B. Town Gas Connection

- Please use approved stainless steel braided flexible tubing bearing SPRING approval marking (e.g. "SPRING APPROVAL GTXXXX") gas cock for connecting from 1/2 inch B.S.P at back of the unit to the gas supply point.

III. Cut-Out Dimensions

Model no.	W	D	R
AGG2780TS AGG2780LS AGG3780TS AGG3780LS	650mm	350mm	120mm
AGG3880TS AGG3880LS	685mm	385mm	120mm

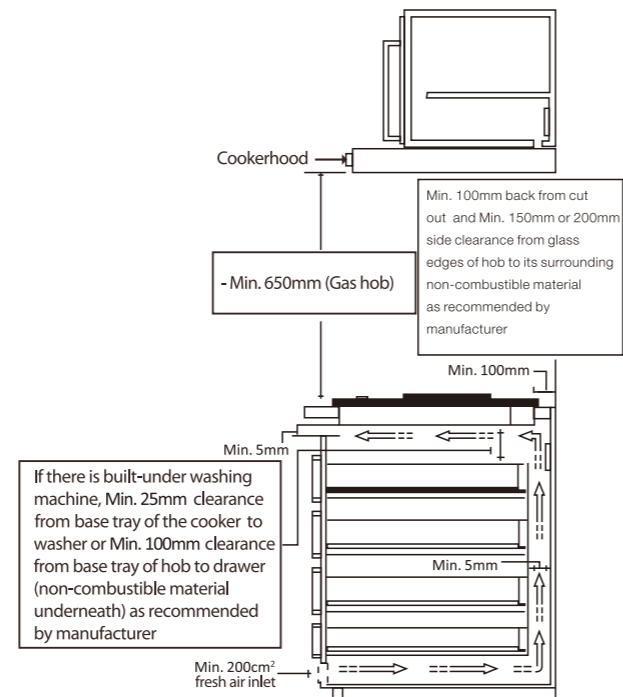
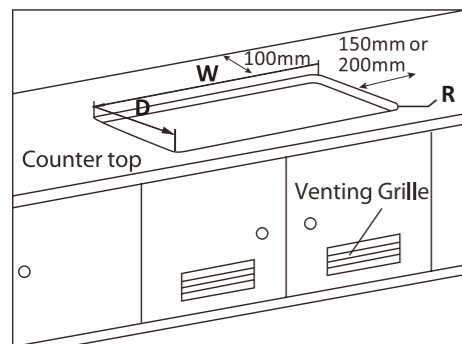

Above diagram is not to scale

IV. Securing The Bottom Casing On To The Bench

Secure the bottom housing to the workbench by securing the 6 screws provided, 2 screws each on the left and right and 2 screws on the rear of the bottom housing (refer below for pictogram and instructions) to prevent the cooktop from shaking during use.

AGG2780TS / AGG2780LS adjustable range (W×D): 650-700 × 350-400(mm)

AGG3780TS / AGG3780LS adjustable range (W×D): 650-700 × 350-400(mm)

AGG3880TS / AGG3880LS adjustable range (W×D): 685-820 × 385-450(mm)

AGG2780TS / AGG2780LS

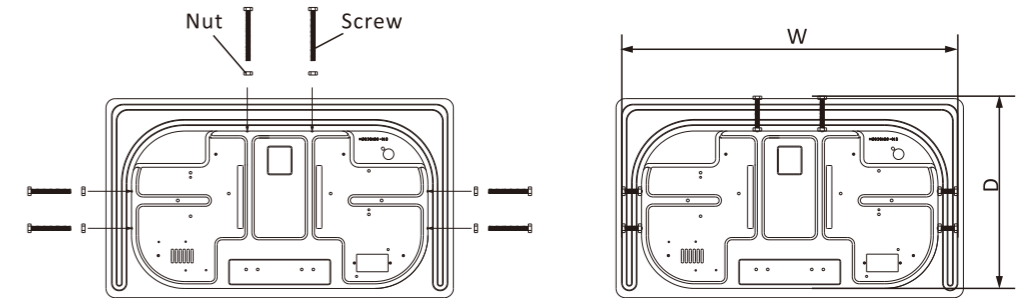

AGG3780TS / AGG3780LS

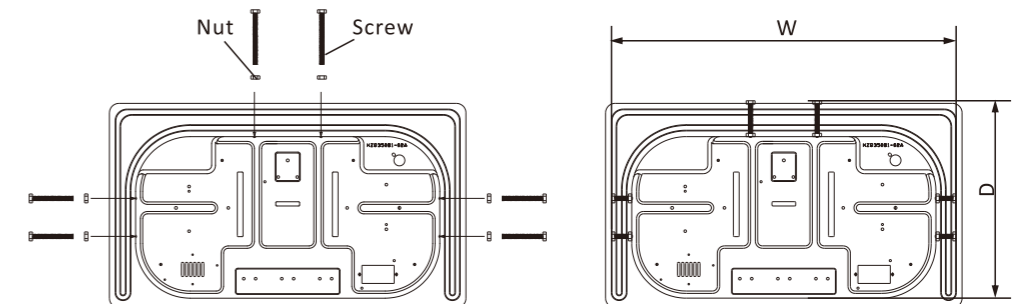

AGG3880TS / AGG3880LS

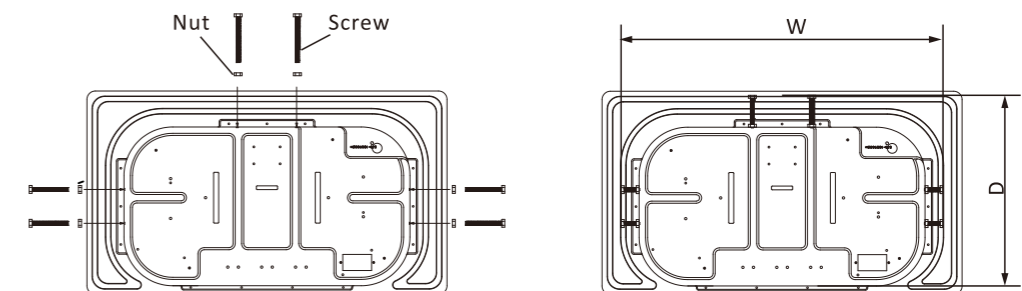

① Place the adjustment screw in the position indicated by the arrow on the bottom housing.

② Adjust the screw size corresponding to the width(W) and depth(D) according to the actual opening size, and fix it with a nut.

IV. Correct Position of Burner Rack & Burner Cap

Make sure that the following parts are fitted properly before use.

1. Burner Rack

Fit Burner Rack legs into Drip Pan (Fig.1). Please do not tilt the placement, otherwise it will affect the flame performance.

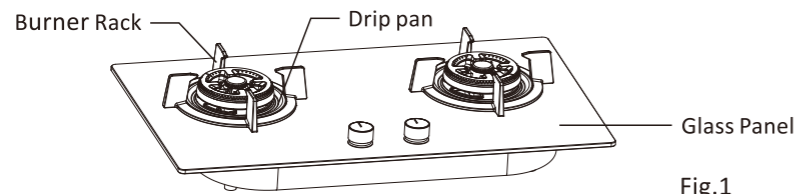

Fig.1

2. Burner head

Install the Wok Burner Inner Cap and Wok Burner Large Cap into the Burner Head (Fig. 2). Ensure both Burner Caps fit exactly into the corresponding slot on the Burner Head (Fig. 3). **Do not tilt or leave gap during installation (Fig. 4).** Incorrect placement of both burner caps will result in the deforming of the burner head, breaking of glass panel, and increase the risk of releasing carbon monoxide (CO).

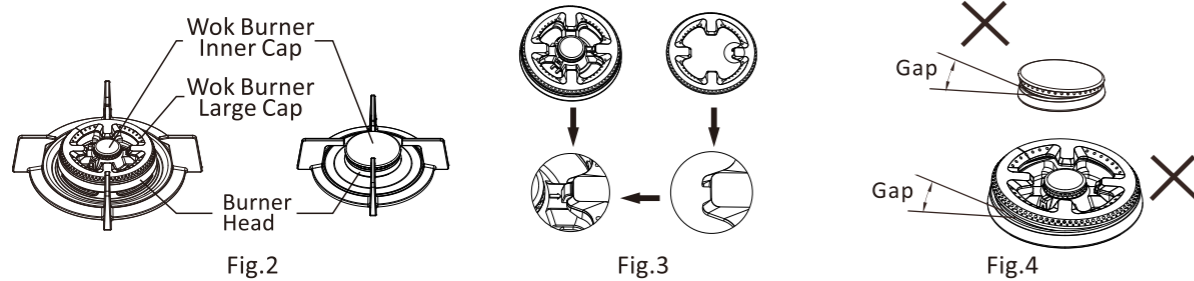

Fig.2

Fig.3

Fig.4

CLEANING TIPS

CLEANING THE HOB SURFACE



WARNING

Close the gas supply valve before cleaning.

- All the enamelled and glass parts should be cleaned with warm water and neutral solution.
- Glass surfaces may be stained by calcareous water or aggressive detergents if left in contact for too long. Any food spills (water, sauce, coffee, etc.) should be wiped away before they dry.
- Clean with warm water and neutral detergent, and then dry with a soft cloth or chamois.
- Do not use abrasive or corrosive products, chlorine-based cleaners or pan scourers.
- Do not use steam cleaning appliances.
- Do not use flammable products.
- Do not leave acid or alkaline substances, such as vinegar, mustard, salt, sugar or lemon juice on the hob.

CLEANING THE HOB PARTS

- Grids, burner caps and burners can be removed for cleaning.
- Clean them by hand with warm water and non-abrasive detergent, removing food residues and ensuring that none of the hole in burner is clogged.
- After cleaning, please ensure the hob is dry before use.
- Reinstall burners and burner caps correctly according to installation diagram.
- When replacing the grids, make sure that the pan stand area is aligned with the burners.
- This model is equipped with electrical ignition plugs and safety device require thorough cleaning of the plug end in order to ensure correct operation. Check these items frequently, and if necessary, clean them with a damp cloth. Any baked-on food should be removed with a toothpick or needle.

NOTE: To avoid damaging the electrical ignition device, do not operate the gas hob when the burners are not in correct position.

SAFEGUARDING THE ENVIRONMENT

Scrapping the product

- By ensuring this product is disposed of correctly, you will help prevent potential negative consequences for the environment and human health, which could otherwise be caused by inappropriate waste handling of this product.

PRODUCT OUTLOOK

AGG2780TS / AGG2780LS

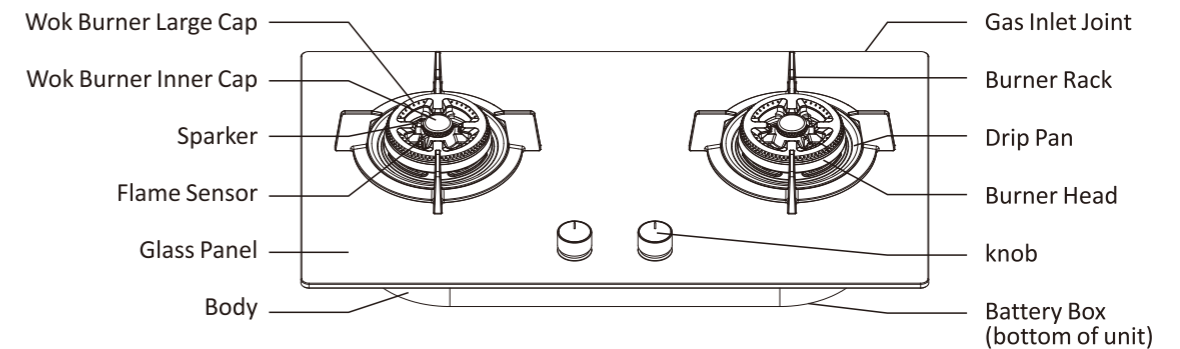

AGG3780TS / AGG3780LS

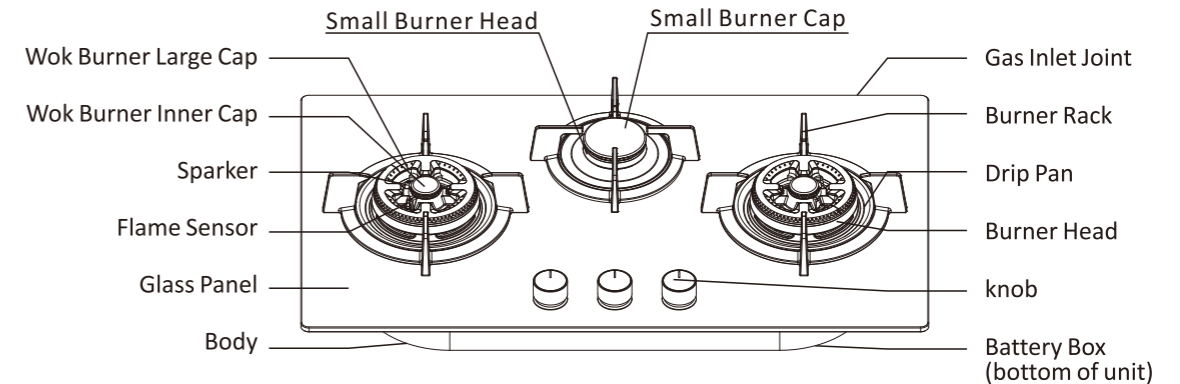

AGG3880TS / AGG3880LS

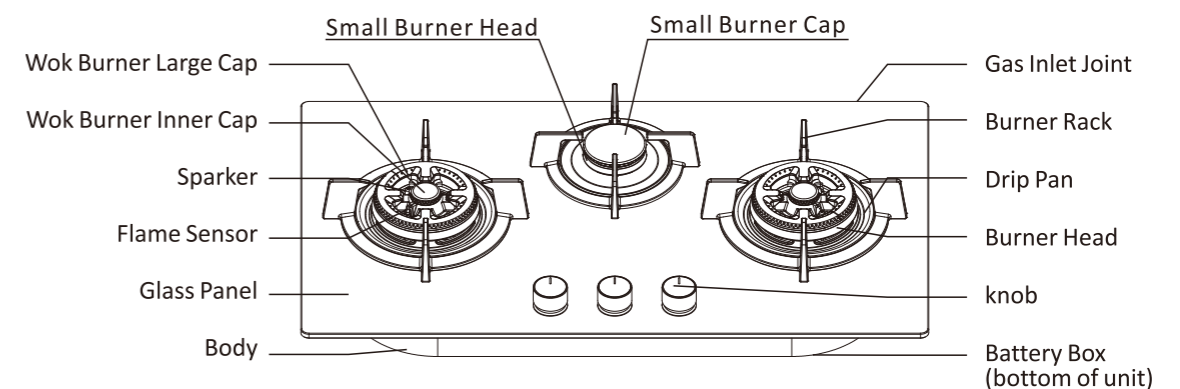

USEFUL ADVICE FOR USING THE BURNERS

This hob has burners of different diameters. For better burner performance, please refer to the following rules:

- Use pots and pans with bottoms of the same width or slightly larger as that of the burners.
- Use the correct amount of water for cooking foods and keep the pot covered.
- Make sure pots on the grates do not protrude beyond the edge of the hob.
- In the event of the burner flames being accidentally extinguished, turn off the burner control and do not attempt to re-ignite the burner for at least 1 min.

IMPORTANT: Improper use of the grids can result in damage to the hob: do not position the grids upside down or slide them across the hob.

Do not use:

- Cast iron griddles, terracotta pots and pans.
- Heat diffusers such as metal mesh, or any other types.
- Two burners simultaneously for one receptacle.

HOW TO USE THE HOB



WARNING

Do not let the burner flame extend beyond the edge of the pan.

IMPORTANT: WHEN THE HOB IS IN USE, THE ENTIRE HOB AREA MAY BECOME HOT.

Attention

Keep natural ventilation windows open or install a mechanical ventilation device (mechanical extractor hood). The use of a gas cooking appliance produce heat and moisture, so it is essential to ensure that the kitchen is well ventilated.



Prolonged intensive use of the appliance may need additional ventilation, for example opening window or increasing the level of mechanical ventilation where present.

The top panel of this cooker is made of tempered glass which is safer than normal glass for this application. However, the following safety precautions for using hob with glass top panel should also be order to prevent the glass top panel from breaking:

1. Clean the burner assembly frequently to maintain a clear gas passage on the flame distributor. Clean and tidy up the flame distributor after spillage of food and liquid once the burner assembly cooled down.
2. Turn off the gas appliance immediately if abnormal noise propagates from the gas appliance and contact gas supply company or gas hob importer for inspection.
3. Do not use oversized utensils for cooking.
4. Do not impact the glass surface with hard objects or place heavy objects on the glass surface.

Do not use additional fitting, such as aluminium foil.

Do not clean the top of the sensor with a hard brush, as it may damage the sensor.

1. While pushing the control knob, turn it to the left (towards the “ ” position) slowly until you hear a ‘click’ sound. Electronic spark will ignite burners. Release your hand after confirm the burner is ignited. The hob has automatic continuous ignition function, do not need to continually push the control knob after ignition. ‘Click’ sound and spark will be stopped automatically after 6-8 seconds.
2. If the flame goes out when you release your hand, repeat the ignition procedure again but try release your hand slowly.
3. Turn Control knob to adjust flame to desirable setting.
4. Flame can be adjusted between “ ” and “ ”. Please adjust flame slowly (Fig.5 & 6).

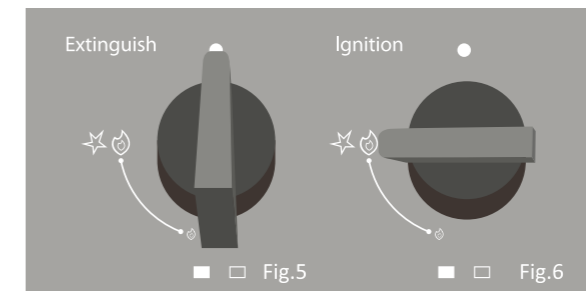

5. Turn the ignition Control Knob backwards to the “ ” position to extinguish the burner.

HOW TO HANDLE SAFETY DEVICE AND CHANGE BATTERY

- If the flame goes out accidentally during operation, the automatic Flame Failure Safety Device will shut off gas supply after a short delay. Turn the knob to “ ” position when this happens.
- The Safety Sensor is very delicate-please do not use hard brushes or rough cleaning pads when cleaning.
- Battery Box is located at bottom (D Size 1.5x1). Open the door of battery box and change battery.
- Put battery at correct polarity (“+” and “-”).

TROUBLESHOOTING GUIDE

If the hob was not operated correctly, please refer to the Troubleshooting Guide to determine the problem before calling the After-Sales Service.

1. The burner fails to ignite or the flame is uneven

Check that:

- The gas cylinder (liquid gas) is not empty.
- The burner openings are not clogged.
- All the burner parts have been positioned correctly.
- Spark electrode is wet especially when humidity level is high.
- Battery needs to be replaced.

2. The burner does not stay lit

Check that:

- When lighting the burner, the knob has been pressed for enough time to activate the protection device.
- The burner openings are not clogged near the thermocouple.
- The end of the safety device is not dirty.

3. The cooking pan or pot are not stable

Check that:

- The bottom of the cooking pan / pot is perfectly flat.
- Cooking pan/pot is correctly positioned at the grid .
- The grids have not been interchanged or positioned incorrectly.

4. Yellow flame

Check that:

- Grease and dirt accumulate on burner head. Wash burner head in warm water with detergent. Mop it dry and then place back in correct position.

5. Smell of gas

Check that:

- Close the gas valve, leave the scene and then call your supplier.

If after the above checks the fault still occurs, get in touch with the nearest After-Sales Service.

TECHNICAL SPECIFICATIONS

Model No.	AGG2780TS	AGG2780LS
Gas Type	G110(Town gas)	G30 (L.P.G.)
Rated Heat Input	ΣQ_n 8.6kW (L:4.3kW R:4.3kW)	ΣQ_n 10kW 728g/h (L:5.0kW R:5.0kW) (L:364g/h R:364g/h)
Injector Size(mm)	L:2.3&1.3 R:2.3&1.3	L:0.94&0.48 R:0.94&0.48
Gas Working Pressure	10mbar	30mbar
Electric Supply	DC1.5V(D-type Battery)	
Ignition Method	Pulse Ignition	
Safety Devices	Yes	
Dimensions	(H)155mm(W)780mm(D)450mm	

Model No.	AGG3780TS	AGG3780LS
Gas Type	G110(Town gas)	G30 (L.P.G.)
Rated Heat Input	ΣQ_n 10.6kW (L:4.3kW M:2.0kW R:4.3kW)	ΣQ_n 12kW 873g/h (L:5.0kW M:2.0kW R:5.0kW) (L:364g/h M:145g/h R:364g/h)
Injector Size(mm)	L:2.3&1.3 M:1.75 R:2.3&1.3	L:0.94&0.48 M:0.66 R:0.94&0.48
Gas Working Pressure	10mbar	30mbar
Electric Supply	DC1.5V(D-type Battery)	
Ignition Method	Pulse Ignition	
Safety Devices	Yes	
Dimensions	(H)155mm(W)780mm(D)450mm	

Model No.	AGG3880TS	AGG3880LS
Gas Type	G110(Town gas)	G30 (L.P.G.)
Rated Heat Input	ΣQ_n 10.6kW (L:4.3kW M:2.0kW R:4.3kW)	ΣQ_n 12kW 873g/h (L:5.0kW M:2.0kW R:5.0kW) (L:364g/h M:145g/h R:364g/h)
Injector Size(mm)	L:2.3&1.3 M:1.75 R:2.3&1.3	L:0.94&0.48 M:0.66 R:0.94&0.48
Gas Working Pressure	10mbar	30mbar
Electric Supply	DC1.5V(D-type Battery)	
Ignition Method	Pulse Ignition	
Safety Devices	Yes	
Dimensions	(H)155mm(W)880mm(D)510mm	

AFTER-SALES SERVICE

Before calling the After-Sales Service, make sure you can give the following information:

SERIAL NO. 0000 000 00000



- type of fault or problem;
- exact model (written on the manual/nameplate);
- serial number (on the nameplate on the bottom of the stove, refer to below pictogram);
- your complete address and phone number.

If any repairs are required, please contact an authorized AFTER-SALES SERVICE in accordance with the warranty instructions.

